

Cassette
YHK

SPRAWDŹ OFERTE



www.astra-automatyka.pl
biuro@astra-automatyka.pl
tel. 22 723 92 29

YHK
YHK-ECM

Cassette Fan Coil Units



Technical Guide - for internal distribution only

CONTENTS

• YHK

- Introduction
- Main components
- EUROVENT Certifications
- Emissions
- Water side pressure drop
- Working conditions
- Dimensions and weights
- Air throw
- Fresh air supply and Air distribution
- Accessories
- Wall electronic controls
- Controls and units for **YHKY-MP** versions
- Electric heater **YHK-E**

Page 3
Page 4
Page 5
Page 6
Page 9
Page 9
Page 10
Page 12
Page 13
Page 14
Page 20
Page 24
Page 25



• YHK-ECM

- Introduction
- Main components
- EUROVENT Certifications
- Emissions
- Water side pressure drop
- Working conditions
- Dimensions and weights
- Air throw
- Accessories
- **YHKY-ECM** configuration
- Wall electronic controls
- Controls and units for **YHKY-ECM-MP** versions
- Electric heater **YHK-ECM-E**

Page 26
Page 27
Page 28
Page 30
Page 34
Page 35
Page 36
Page 38
Page 39
Page 41
Page 42
Page 44
Page 45



• YHK / YHK-ECM

- **MP** electronic board
- **JTM-B** wall mounted control
- **RT03** infra-red remote control
- **PSM-DI** multifunction control
- **NET** management system
- PSM-DI and NET accessories

Page 46
Page 47
Page 48
Page 50
Page 51
Page 55

• YHK Cassette OCA

- Introduction
- Dimensions and weights
- Assembly diagram
- Components of the casing
- Valve kit

Page 56
Page 57
Page 58
Page 59
Page 59



Johnson Controls take part to the Eurovent program of fan coil performance certification. The official figures are published in the web site www.eurovent-certification.com. The tested performances are:

- Cooling total emission at the following conditions:

- Water temperature	+7°C E.W.T.	+12°C L.W.T.
- Entering air temperature	+27°C dry bulb	+19°C wet bulb
- Heating emission (2 pipe units) at the following conditions:

- Water temperature	+45°C E.W.T.	+40°C L.W.T.
- Entering air temperature	+20°C	

- Cooling sensible emission at the following conditions:

- Water temperature	+7°C E.W.T.	+12°C L.W.T.
- Entering air temperature	+27°C dry bulb	+19°C wet bulb
- Heating emission (4 pipe units) at the following conditions:

- Water temperature	+65°C E.W.T.	+55°C L.W.T.
- Entering air temperature	+20°C	

• Fan absorption

• Water pressure drop

• Sound power

Innovating and beautiful design, seven different sizes, high control flexibility, easy maintenance: the new YHK chilled water cassette is the result of an extended technical and design development aimed at achieving the highest level in terms of performance, silent operation and control possibilities.

The air diffuser has an highly attractive aesthetical appearance, very innovative, and is also able to offer the best air distribution performance thanks to long computer studies and laboratory tests. The standard colour is RAL 9003, other colours available on request.

The 4 smaller sizes are designed to fit into 600x600 mm false ceiling standard modules. The 3 bigger sizes have a dimension of 800x800 mm which allows the best outcome in terms of quietness and of price/performance ratio for these high capacity models.

Every unit can be supplied with 1 coil (2 pipe system) and a possible electric heater or with 2 coils (4 pipe system). Each model can have fresh air intake and a remote air diffuser can be connected to the unit.

The condensate pump is integral with the unit, is very quiet and has a maximum head of 650 mm.

In addition to temperature and speed standard controls, automatic speed selection is also available. More than one unit can be connected to a single control, and the unit control panel can be installed in a remote position that facilitates the maintenance operation. All the YHK units can be supplied in MP version. This version allows a wide range of controls, including the infra-red remote control, which can manage one single unit or several units by using the Modbus RTU - RS 485 communication protocol.

The units can be connected to the most common automatic building management systems.

Finally, each unit can be equipped with a low energy consumption electric motor that is controlled by an inverter card that makes possible continuous air flow variations.



INTAKE GRID AND DISTRIBUTION OF THE AIR

Intake grids, frame and adjustable air distribution louvers on each side, made from ABS.

AKPA version: white ABS, RAL 9003

AKPB version: with intake grid, frame and louvers, choice of one colour only

AKPC version: with intake grid and louvers, choice of one colour, plus white ABS frame RAL 9003

AKPD version: with louvers, choice of one colour, while the grid and frame are made from ABS, RAL 9003

MD-600/MD-800 version: metal diffuser painted in RAL 9003 white colour with 600x600 dimension to perfectly fit into the false ceiling standard modules without overlapping parts.

CASING

Is made from galvanized steel with internal thermal insulation with polyolefin (PO) foam (class M1) and external anti-condensate lining.

CONTROL PANEL

Made of an external box with the control electronic board with an easily accessible terminal board.

FAN ASSEMBLY

The fan assembly, which is mounted on anti-vibrating supports, is extremely silent.

The radial fan has been designed to optimise performance, using wing profile blades with a shape that reduces turbulence, increasing efficiency and reducing noise.

The single air inlet radial fan is connected to a 6 speed electric motor with single phase 230V/50Hz supply, class B insulation and integrated Klixon thermal contact for motor protection.

The units are supplied with 3 standard speeds connected and it is possible to change them on site if necessary.

COIL

Made of copper tubes with bonded aluminium fins for maximum transfer contact.

The coil has 1, 2 or 3 rows for 2 pipe models and 2+1 rows for 4 pipe models (the heating row is on the inside part of the coil).

For 4 pipe systems two versions are available:

YHK 20-4, YHK 25-4, YHK 40-4, YHK 50-4, YHK 65-4, YHK 95-4, YHK 110-4 supply an higher heating emission;

YHK 40-6, YHK 50-6, YHK 95-6, YHK 110-6 supply an higher cooling emission.

The heat exchanger is not suitable for use in corrosive atmosphere or in environments where aluminium may be subject to corrosion.

CONDENSATE COLLECTION TRAY

High density ABS polystyrene foam condensate tray, shaped in order to optimize the air diffusion, fire retardant rating B1 to DIN 4102.

AIR FILTER

Synthetic washable filter, easily removable.

CONDENSATE PUMP

Float switch centrifugal pump with 650 mm of maximum head, integral to the unit and wired to the control panel on the outside of the casing.

VALVE SET

Two or three way valves for ON/OFF operation, with pipe mounting kit and thermostatic actuator.

Technical features

2 pipe units. The following standard rating conditions are used:

COOLING

Entering air temperature +27°C d.b. +19°C w.b.
Water temperature +7°C E.W.T. +12°C L.W.T.

HEATING

Entering air temperature +20°C
Water temperature +45°C E.W.T. +40°C L.W.T.

YHK MODEL		20-2			25-2			40-2			50-2			65-2			95-2			110-2		
Speed		1	2	3	1	2	3	1	2	3	1	2	3	1	2	3	1	2	3	1	2	3
Air flow	m³/h	310	420	610	310	420	520	320	500	710	430	610	880	630	820	1140	710	970	1500	710	1280	1820
Cooling total emission (E)	kW	1,25	1,60	1,92	1,82	2,31	2,64	2,23	3,30	4,26	2,91	3,82	4,93	4,18	4,86	6,08	5,27	6,72	9,39	5,27	8,36	10,93
Cooling sensible emission (E)	kW	0,99	1,29	1,58	1,33	1,72	2,00	1,55	2,35	3,11	2,05	2,75	3,65	3,00	3,53	4,51	3,42	4,42	6,36	3,67	6,00	8,08
Heating (E)	kW	1,38	1,80	2,24	1,85	2,42	2,80	2,12	3,28	4,37	2,85	3,85	5,15	4,27	5,03	6,50	4,92	6,40	9,23	5,12	8,55	11,72
Dp Cooling (E)	kPa	4,5	7,0	10,0	4,9	7,6	9,7	6,4	13,0	20,9	7,5	12,4	19,7	10,9	14,3	21,6	9,4	14,7	26,9	9,4	21,8	35,6
Dp Heating (E)	kPa	4,4	7,2	10,7	4,3	6,9	9,0	2,8	6,1	10,2	6,2	10,6	17,8	7,0	9,4	15,0	7,1	11,4	22,0	7,6	19,2	33,8
Sound power Lw (E)	dB(A)	33	40	49	33	40	45	33	45	53	41	49	59	33	40	48	34	40	53	34	48	58
Sound pressure Lp (*)	dB(A)	24	31	40	24	31	36	24	36	44	32	40	50	24	31	39	25	31	44	25	39	49
Fan (E)	W	25	32	57	25	32	44	25	44	68	32	57	90	33	48	77	42	63	120	42	95	170
	A	0,11	0,15	0,27	0,11	0,15	0,20	0,11	0,20	0,32	0,15	0,27	0,45	0,15	0,23	0,36	0,18	0,28	0,53	0,18	0,42	0,74
Water content	l	0,8			1,4			2,1			2,1			3,0			4,0			4,0		
Dimensions	mm	575 x 575 x 275															820 x 820 x 303					

4 pipe units. The following standard rating conditions are used:

COOLING

Entering air temperature +27°C d.b. +19°C w.b.
Water temperature +7°C E.W.T. +12°C L.W.T.

HEATING

Entering air temperature +20°C
Water temperature +65°C E.W.T. +55°C L.W.T.

YHK MODEL		20-4			25-4			40-4			40-6			50-4			50-6		
Speed		1	2	3	1	2	3	1	2	3	1	2	3	1	2	3	1	2	3
Air flow	m³/h	310	420	610	310	420	520	310	500	710	320	500	710	430	610	880	430	610	880
Cooling total emission (E)	kW	1,49	1,93	2,27	1,83	2,33	2,66	1,83	2,61	3,27	2,07	3,02	3,86	2,33	2,96	3,72	2,69	3,47	4,44
Cooling sensible emission (E)	kW	1,13	1,52	1,84	1,32	1,68	1,94	1,32	1,94	2,49	1,47	2,20	2,88	1,72	2,23	2,88	1,94	2,56	3,37
Dp Cooling (E)	kPa	6,0	10,0	13,5	4,6	6,9	8,8	4,6	8,8	13,4	4,0	7,0	10,5	7,2	11,2	17,0	6,0	9,0	14,0
Heating (E)	kW	1,72	2,23	2,66	2,13	2,66	3,04	2,13	3,04	3,86	1,73	2,71	2,91	2,61	3,33	4,19	2,14	2,66	3,29
Dp Heating (E)	kPa	5,2	8,3	11,4	4,6	6,8	8,7	4,6	8,7	13,3	2,6	4,6	6,7	6,4	9,9	15,0	3,9	5,7	8,4
Sound power Lw (E)	dB(A)	33	40	49	33	40	45	33	45	53	33	45	53	41	49	59	41	49	59
Sound pressure Lp (*)	dB(A)	24	31	40	24	31	36	24	36	44	24	36	44	32	40	50	32	40	50
Fan (E)	W	25	32	57	25	32	44	25	44	68	25	44	68	32	57	90	32	57	90
	A	0,11	0,15	0,27	0,11	0,15	0,20	0,11	0,20	0,32	0,11	0,20	0,32	0,15	0,27	0,45	0,15	0,27	0,45
Cooling water content	l	1,0			1,4			1,4			1,7			1,4			1,7		
Heating water content	l	0,6			0,7			0,7			0,5			0,7			0,5		
Dimensions	mm	575 x 575 x 275																	

YHK MODEL		65-4			95-4			95-6			110-4			110-6		
Speed		1	2	3	1	2	3	1	2	3	1	2	3	1	2	3
Air flow	m³/h	630	820	1140	710	970	1500	710	970	1500	710	1280	1820	710	1225	1730
Cooling total emission (E)	kW	4,11	4,98	6,26	4,48	5,60	7,59	4,95	6,27	8,65	4,48	6,84	8,72	4,95	7,75	9,69
Cooling sensible emission (E)	kW	2,93	3,60	4,61	3,21	4,09	5,71	3,49	4,49	6,37	3,21	5,09	6,67	3,49	5,64	7,26
Dp Cooling (E)	kPa	8,8	12,5	18,9	10,3	15,4	26,9	9,0	14,0	25,0	10,3	22,1	34,7	9,0	20,0	32,0
Heating (E)	kW	5,21	6,33	8,02	5,69	7,15	9,66	4,59	5,63	7,50	5,69	8,80	11,16	4,59	6,78	9,48
Dp Heating (E)	kPa	7,9	11,2	17,2	9,3	14,0	24,0	4,9	7,0	11,8	9,3	20,3	31,2	4,9	9,9	15,0
Sound power Lw (E)	dB(A)	33	40	48	34	40	53	34	40	53	34	48	58	34	48	58
Sound pressure Lp (*)	dB(A)	24	31	39	25	31	44	25	31	44	25	39	49	25	39	49
Fan (E)	W	33	48	77	42	63	120	42	63	120	42	95	170	42	95	170
	A	0,15	0,23	0,36	0,18	0,28	0,53	0,18	0,28	0,53	0,18	0,42	0,74	0,18	0,42	0,74
Cooling water content	l	3,0			3,0			3,6			3,0			3,6		
Heating water content	l	1,4			1,4			1,0			1,4			1,1		
Dimensions	mm	820 x 820 x 303														

Condensate pump absorption: 10 W

(E) = Eurovent certified performance.

(*) = The sound pressure levels are 9 dB(A) lower than the sound power levels and apply to the reverberant field of a 100 m³ room and a reverberation time of 0.5 sec.

Cooling emission of 1 coil units (2 pipe installation)

Entering air temperature: +27°C d.b. – +19°C w.b.

Mod.	Speed	Qv m³/h	WT: 5/10 °C				WT: 7/12 °C			WT: 9/14 °C			WT: 12/17 °C		
			Qw l/h	Pc kW	Ps kW	Qw l/h	Pc kW	Ps kW	Qw l/h	Pc kW	Ps kW	Qw l/h	Pc kW	Ps kW	
YHK 20-2	MAX	610	421	2,39	1,77	340	1,92	1,58	254	1,41	1,39	199	1,10	1,10	
	MED	420	346	1,98	1,45	280	1,60	1,29	210	1,22	1,16	160	0,90	0,90	
	MIN	310	269	1,55	1,12	219	1,25	0,99	165	0,96	0,89	123	0,69	0,69	
YHK 25-2	MAX	520	554	3,18	2,18	462	2,64	2,00	362	2,10	1,75	252	1,43	1,43	
	MED	420	482	2,77	1,88	403	2,31	1,72	317	1,84	1,50	220	1,25	1,25	
	MIN	310	417	2,40	1,62	317	1,82	1,30	276	1,61	1,29	188	1,07	1,07	
YHK 40-2	MAX	710	926	5,31	3,57	745	4,26	3,11	617	3,59	2,87	420	2,37	2,37	
	MED	500	715	4,11	2,73	575	3,30	2,35	483	2,81	2,18	319	1,82	1,82	
	MIN	320	508	2,93	1,92	387	2,23	1,55	349	2,03	1,53	225	1,29	1,29	
YHK 50-2	MAX	880	1049	6,01	4,08	863	4,93	3,65	694	4,03	3,29	479	2,70	2,70	
	MED	610	835	4,79	3,20	667	3,82	2,75	559	3,25	2,57	376	2,13	2,13	
	MIN	430	633	3,65	2,41	506	2,91	2,05	430	2,50	1,92	283	1,62	1,62	
YHK 65-2	MAX	1140	1264	7,27	4,92	1060	6,08	4,40	840	4,88	3,95	573	3,25	3,25	
	MED	820	1003	5,78	3,87	845	4,86	3,45	674	3,92	3,09	453	2,58	2,58	
	MIN	630	858	4,96	3,29	722	4,18	2,94	580	3,37	2,62	384	2,20	2,20	
YHK 95-2	MAX	1500	1943	11,18	7,47	1635	9,39	6,36	1301	7,57	5,99	880	5,00	5,00	
	MED	970	1374	7,93	5,21	1166	6,72	4,42	939	5,46	4,15	612	3,50	3,50	
	MIN	710	1070	6,18	4,02	913	5,27	3,42	740	4,30	3,20	434	2,48	2,48	
YHK 110-2	MAX	1820	2277	13,07	8,84	1909	10,93	7,90	1511	8,78	7,11	1044	5,90	5,90	
	MED	1280	1722	9,92	6,59	1454	8,36	5,89	1162	6,75	5,27	775	4,42	4,42	
	MIN	710	1070	6,18	4,02	913	5,27	3,60	740	4,30	3,20	434	2,48	2,48	

Heating emission of 1 coil units (2 pipe installation)

Entering air temperature: +20°C

Mod.	Speed	Qv m³/h	WT: 45/40 °C			WT: 50/40 °C		WT: 60/50 °C		WT: 70/60 °C		WT: 80/70 °C	
			Qw l/h	Ph kW	Qw l/h	Ph kW	Qw l/h	Ph kW	Qw l/h	Ph kW	Qw l/h	Ph kW	
YHK 20-2	MAX	610	386	2,24	203	2,37	298	3,46	393	4,56	488	5,67	
	MED	420	310	1,80	164	1,91	239	2,78	315	3,66	391	4,55	
	MIN	310	237	1,38	126	1,46	183	2,13	240	2,80	298	3,47	
YHK 25-2	MAX	520	482	2,80	266	3,10	377	4,39	488	5,68	599	6,97	
	MED	420	417	2,42	232	2,69	327	3,80	422	4,91	513	5,96	
	MIN	310	356	2,07	198	2,31	279	3,25	360	4,19	441	5,12	
YHK 40-2	MAX	710	787	4,57	440	5,12	619	7,19	795	9,25	972	11,30	
	MED	500	593	3,45	334	3,89	467	5,43	598	6,96	730	8,48	
	MIN	320	412	2,39	235	2,73	326	3,79	415	4,83	505	5,87	
YHK 50-2	MAX	880	903	5,25	504	5,86	709	8,25	914	10,63	1118	13,00	
	MED	610	702	4,08	394	4,58	552	6,42	709	8,25	866	10,07	
	MIN	430	520	3,02	294	3,42	410	4,77	524	6,10	639	7,43	
YHK 65-2	MAX	1140	1118	6,50	624	7,26	878	10,21	1130	13,14	1383	16,08	
	MED	820	865	5,03	486	5,65	681	7,92	874	10,16	1067	12,41	
	MIN	630	734	4,27	415	4,82	578	6,72	741	8,61	903	10,50	
YHK 95-2	MAX	1500	1683	9,78	951	11,06	1327	15,43	1699	19,76	2071	24,08	
	MED	970	1146	6,67	655	7,62	906	10,54	1155	13,43	1403	16,32	
	MIN	710	876	5,09	505	5,87	694	8,07	882	10,25	1068	12,42	
YHK 110-2	MAX	1820	2015	11,72	1132	13,17	1586	18,45	2037	23,68	2486	28,91	
	MED	1280	1471	8,55	834	9,70	1161	13,50	1484	17,26	1807	21,01	
	MIN	710	876	5,09	505	5,87	694	8,07	882	10,25	1068	12,42	

Emission correction factors for different working conditions

Multiply the factors by the emission figures in the 7-12°C table above.

Note: the correction factors are indicative, as they are average values.

Water (°C)	Air (°C)	TOTAL EMISSION			Air (°C)	SENSIBLE EMISSION		
		25-18	26-18.5	28-20		25-18	26-18.5	28-20
7/12	K	0,82	0,89	1,11	K	0,90	0,94	1,06
10/15	K	0,56	0,63	0,82	K	0,72	0,78	0,90
14/18	K	0,35	0,41	0,52	K	0,50	0,58	0,72

LEGEND

- WT = Water temperature
- Pc = Cooling total emission
- Ps = Cooling sens. emission
- Ph = Emission
- Qw = Water flow
- Speed = Fan speed
- MAX = High speed
- MED = Medium speed
- MIN = Low speed
- Qv = Air flow

Cooling emission of 2 coil units (4 pipe installation)

Entering air temperature: +27°C d.b. – +19°C w.b.

Mod.	Speed	WT: 5/10 °C				WT: 7/12 °C			WT: 9/14 °C			WT: 12/17 °C		
		Qv m³/h	Qw l/h	Pc kW	Ps kW	Qw l/h	Pc kW	Ps kW	Qw l/h	Pc kW	Ps kW	Qw l/h	Pc kW	Ps kW
YHK 20-4	MAX	610	490	2,79	2,06	401	2,27	1,84	307	1,78	1,69	239	1,33	1,33
	MED	420	410	2,35	1,70	337	1,93	1,52	260	1,51	1,37	196	1,11	1,11
	MIN	310	314	1,80	1,27	260	1,49	1,13	201	1,17	1,02	148	0,84	0,84
YHK 25-4	MAX	520	569	3,27	2,22	465	2,66	1,94	374	2,18	1,79	260	1,47	1,47
	MED	420	465	2,68	1,80	405	2,33	1,68	309	1,80	1,44	210	1,19	1,19
	MIN	310	398	2,29	1,53	318	1,83	1,32	267	1,55	1,22	177	1,01	1,01
YHK 40-4	MAX	710	718	4,11	2,84	574	3,27	2,49	467	2,72	2,30	330	1,85	1,85
	MED	500	569	3,27	2,22	455	2,61	1,94	374	2,18	1,79	260	1,47	1,47
	MIN	320	398	2,29	1,53	318	1,83	1,32	267	1,55	1,22	177	1,01	1,01
YHK 50-4	MAX	880	791	4,51	3,14	656	3,72	2,88	512	2,98	2,56	366	2,04	2,04
	MED	610	632	3,61	2,47	520	2,96	2,23	413	2,40	2,00	288	1,61	1,61
	MIN	430	510	2,94	1,98	405	2,33	1,72	337	1,96	1,59	231	1,32	1,32
YHK 65-4	MAX	1140	1299	7,47	5,04	1090	6,26	4,50	864	5,02	4,04	586	3,33	3,33
	MED	820	1027	5,92	3,95	866	4,98	3,52	691	4,02	3,15	462	2,63	2,63
	MIN	630	842	4,86	3,21	713	4,11	2,87	572	3,33	2,56	374	2,14	2,14
YHK 95-4	MAX	1500	1588	9,11	6,23	1327	7,59	5,57	1046	6,08	5,02	726	4,10	4,10
	MED	970	1158	6,67	4,47	974	5,60	4,00	775	4,50	3,57	524	2,99	2,99
	MIN	710	920	5,31	3,52	778	4,48	3,15	623	3,62	2,81	411	2,35	2,35
YHK 110-4	MAX	1820	1836	10,50	7,26	1529	8,72	6,49	1199	6,97	5,98	849	4,77	4,77
	MED	1280	1423	8,18	5,55	1191	6,84	4,96	942	5,48	4,46	646	3,66	3,66
	MIN	710	920	5,31	3,52	778	4,48	3,15	623	3,62	2,81	411	2,35	2,35

Heating emission of 2 coil units (4 pipe installation)

Entering air temperature: +20°C

Mod.	Speed	WT: 45/40 °C			WT: 50/40 °C		WT: 60/50 °C		WT: 70/60 °C		WT: 80/70 °C	
		Qv m³/h	Qw l/h	Ph kW	Qw l/h	Ph kW	Qw l/h	Ph kW	Qw l/h	Ph kW	Qw l/h	Ph kW
YHK 20-4	MAX	610	256	1,49	134	1,56	197	2,29	261	3,03	325	3,78
	MED	420	215	1,25	113	1,31	166	1,93	219	2,54	272	3,17
	MIN	310	166	0,96	87	1,01	128	1,49	169	1,96	210	2,44
YHK 25-4	MAX	520	283	1,65	149	1,73	218	2,54	298	3,46	358	4,17
	MED	420	247	1,44	130	1,51	191	2,22	260	3,02	312	3,63
	MIN	310	196	1,14	103	1,20	151	1,76	209	2,43	247	2,87
YHK 40-4	MAX	710	351	2,04	184	2,14	270	3,14	378	4,40	444	5,17
	MED	500	277	1,61	146	1,69	214	2,48	298	3,46	350	4,07
	MIN	320	196	1,14	103	1,20	151	1,76	209	2,43	247	2,87
YHK 50-4	MAX	880	402	2,34	211	2,45	310	3,60	426	4,95	510	5,93
	MED	610	317	1,84	166	1,94	244	2,84	341	3,97	401	4,67
	MIN	430	247	1,44	130	1,51	191	2,22	267	3,10	312	3,63
YHK 65-4	MAX	1140	771	4,48	410	4,76	596	6,93	783	9,10	970	11,28
	MED	820	609	3,54	324	3,77	471	5,48	618	7,19	766	8,90
	MIN	630	501	2,91	267	3,11	388	4,51	508	5,91	629	7,31
YHK 95-4	MAX	1500	929	5,40	493	5,73	718	8,34	946	11,00	1170	13,60
	MED	970	686	3,99	365	4,25	531	6,17	697	8,10	864	10,04
	MIN	710	547	3,18	291	3,39	423	4,92	555	6,45	686	7,98
YHK 110-4	MAX	1820	1074	6,24	569	6,61	829	9,64	1092	12,70	1353	15,74
	MED	1280	845	4,91	449	5,22	653	7,60	858	9,98	1064	12,37
	MIN	710	547	3,18	291	3,39	423	4,92	555	6,45	686	7,98

Emission correction factors for different working conditions

Multiply the factors by the emission figures in the 7-12°C table above.

Note: the correction factors are indicative, as they are average values.

Water (°C)	Air (°C)	TOTAL EMISSION			SENSIBLE EMISSION			
		25-18	26-18.5	28-20	Air (°C)	25-18	26-18.5	28-20
7/12	K	0,82	0,89	1,11	K	0,90	0,94	1,06
10/15	K	0,56	0,63	0,82	K	0,72	0,78	0,90
14/18	K	0,35	0,41	0,52	K	0,50	0,58	0,72

LEGEND

- WT = Water temperature
- Pc = Cooling total emission
- Ps = Cooling sens. emission
- Ph = Emission
- Qw = Water flow
- Speed = Fan speed
- MAX = High speed
- MED = Medium speed
- MIN = Low speed
- Qv = Air flow

Cooling emission of 2 coil units (4 pipe installation)

Entering air temperature: +27°C d.b. – +19°C w.b.

Mod.	Speed	Qv m³/h	WT: 5/10 °C				WT: 7/12 °C			WT: 9/14 °C			WT: 12/17 °C		
			Qw l/h	Pc kW	Ps kW	Qw l/h	Pc kW	Ps kW	Qw l/h	Pc kW	Ps kW	Qw l/h	Pc kW	Ps kW	
YHK 40-6	MAX	710	812	4,65	3,22	664	3,86	2,88	528	3,00	2,53	378	2,13	2,13	
	MED	500	629	3,62	2,47	519	3,02	2,20	415	2,37	1,93	288	1,63	1,63	
	MIN	320	425	2,45	1,64	355	2,07	1,47	287	1,65	1,29	192	1,10	1,10	
YHK 50-6	MAX	880	940	5,37	3,77	764	4,44	3,37	606	3,43	2,96	442	2,48	2,48	
	MED	610	729	4,18	2,87	597	3,47	2,56	477	2,71	2,25	337	1,90	1,90	
	MIN	430	557	3,21	2,18	462	2,69	1,94	370	2,12	1,70	256	1,46	1,46	
YHK 95-6	MAX	1500	1804	10,37	7,13	1488	8,65	6,37	1189	6,79	5,60	836	4,74	4,74	
	MED	970	1291	7,44	5,02	1078	6,27	4,49	867	4,98	3,94	587	3,35	3,35	
	MIN	710	1012	5,85	3,90	851	4,95	3,49	689	3,96	3,06	459	2,63	2,63	
YHK 110-6	MAX	1820	2105	12,07	8,40	1725	10,03	7,51	1375	7,82	6,60	987	5,57	5,57	
	MED	1280	1607	9,25	6,32	1332	7,75	5,64	1066	6,11	4,96	739	4,21	4,21	
	MIN	710	1012	5,85	3,90	851	4,95	3,49	689	3,96	3,06	459	2,63	2,63	

Heating emission of 2 coil units (4 pipe installation)

Entering air temperature: +20°C

Mod.	Speed	Qv m³/h	WT: 45/40 °C			WT: 50/40 °C		WT: 60/50 °C		WT: 70/60 °C		WT: 80/70 °C	
			Qw l/h	Ph kW	Qw l/h	Ph kW	Qw l/h	Ph kW	Qw l/h	Ph kW	Qw l/h	Ph kW	
YHK 40-6	MAX	710	279	1,62	139	1,61	213	2,48	288	3,35	363	4,22	
	MED	500	226	1,32	113	1,32	173	2,01	233	2,71	294	3,42	
	MIN	320	165	0,96	83	0,97	127	1,47	170	1,98	214	2,49	
YHK 50-6	MAX	880	315	1,83	156	1,82	241	2,80	326	3,79	411	4,78	
	MED	610	255	1,48	127	1,48	195	2,27	263	3,06	332	3,86	
	MIN	430	205	1,19	103	1,20	157	1,83	212	2,46	266	3,10	
YHK 95-6	MAX	1500	720	4,18	493	4,33	554	6,44	736	8,56	919	10,69	
	MED	970	541	3,14	365	3,27	416	4,84	552	6,42	689	8,01	
	MIN	710	441	2,56	291	2,67	340	3,95	450	5,23	561	6,52	
YHK 110-6	MAX	1820	824	4,79	569	6,61	633	7,36	843	9,80	1053	12,24	
	MED	1280	651	3,79	449	5,22	501	5,83	666	7,74	831	9,66	
	MIN	710	441	2,56	291	3,39	340	3,95	450	5,23	561	6,52	

Emission correction factors for different working conditions

Multiply the factors by the emission figures in the 7-12°C table above.

Note: the correction factors are indicative, as they are average values.

Water (°C)	Air (°C)	TOTAL EMISSION			Air (°C)	SENSIBLE EMISSION		
		25 - 18	26 - 18.5	28 - 20		25 - 18	26 - 18.5	28 - 20
7/12	K	0,82	0,89	1,11	K	0,90	0,94	1,06
10/15	K	0,56	0,63	0,82	K	0,72	0,78	0,90
14/18	K	0,35	0,41	0,52	K	0,50	0,58	0,72

LEGEND

- WT = Water temperature
- Pc = Cooling total emission
- Ps = Cooling sens. emission
- Ph = Emission
- Qw = Water flow
- Speed = Fan speed
- MAX = High speed
- MED = Medium speed
- MIN = Low speed
- Qv = Air flow

2 pipe installation

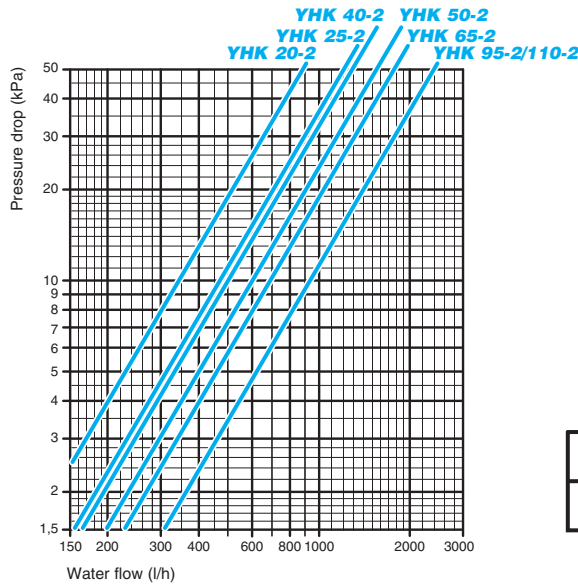

The water pressure drop figures refer to a mean water temperature of **10°C**; for different temperatures, multiply the pressure drop figures by the correction factors **K**.

°C	20	30	40	50	60	70	80
K	0,94	0,90	0,86	0,82	0,78	0,74	0,70

4 pipe installation

Pressure drop for cooling coil

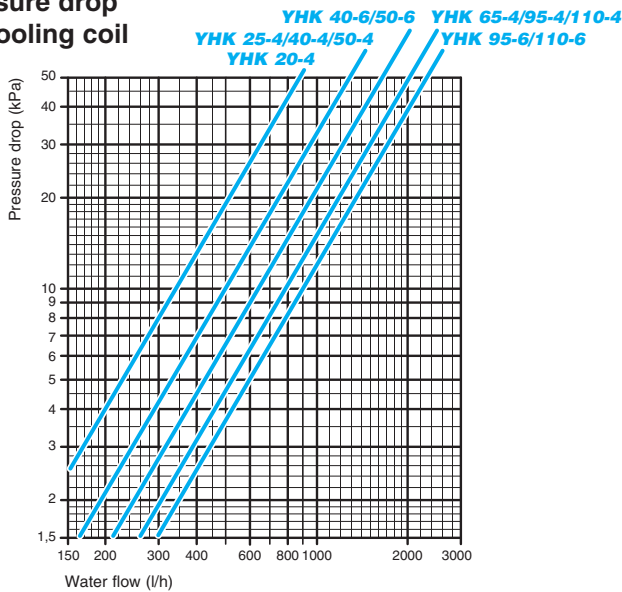

The water pressure drop figures refer to a mean water temperature of **10°C**; for different temperatures, multiply the pressure drop figures by the correction factors **K**.

°C	20	30	40	50	60	70	80
K	0,94	0,90	0,86	0,82	0,78	0,74	0,70

Pressure drop for heating coil

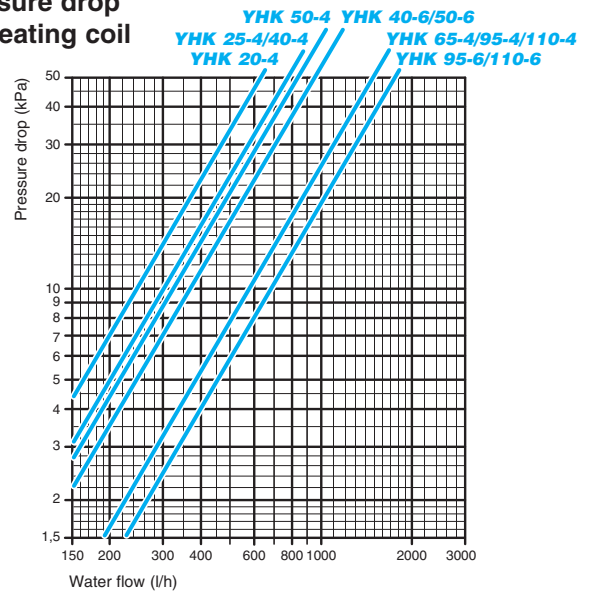

The water pressure drop figures refer to a mean water temperature of **60°C**; for different temperatures, multiply the pressure drop figures by the correction factors **K**.

°C	40	50	70	80
K	1,12	1,06	0,94	0,88

Working conditions

Water flow	MAX. working pressure: 8 bars
Air flow	Suitable relative humidity: 15-75%
Supply	Single phase 230V / 50Hz
Installation	MAX. height: see table on page 12

MIN. entering water temperature: +5°C
MAX. entering water temperature: +80°C
MIN. entering air temperature: +6°C
MAX. entering air temperature: +40°C

YHK 20/25/40/50-2 / YHK 20/25/40/50-4 / YHK 40/50-6 (Version 600 x 600)

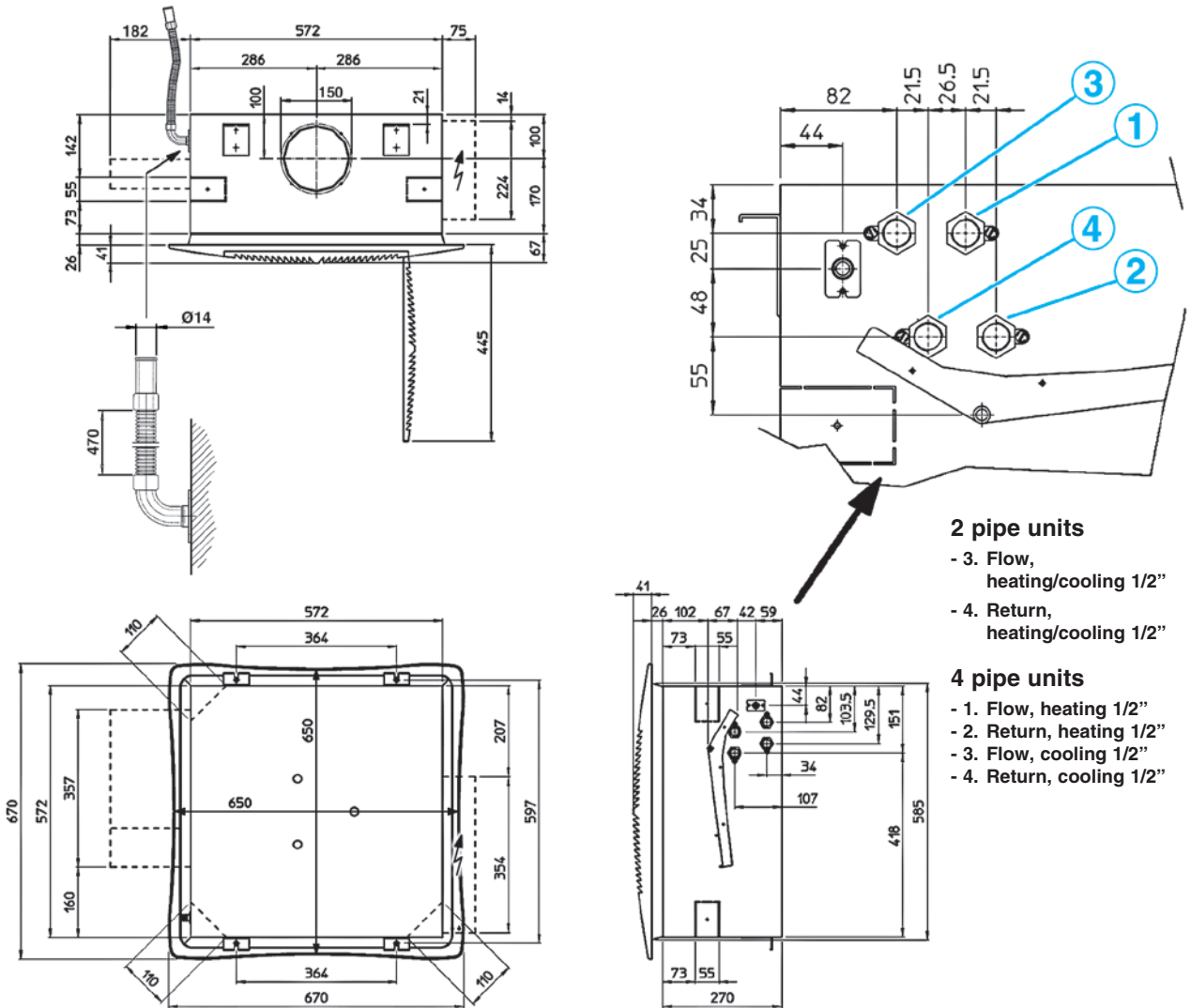

**MD-600/MD-800
METAL DIFFUSER**

(RS receiver, Code 9066338, for MD-600/MD-800 metal diffuser for MP units)

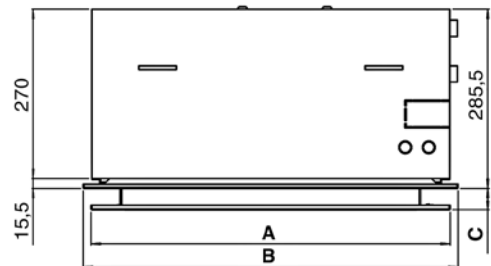
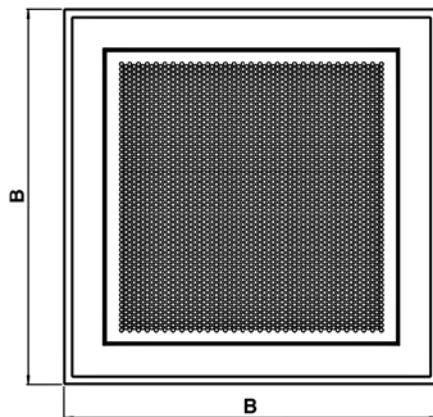

Size	A	B	C	Code
MD-600	574	599	34,5	9079420
MD-800	845	880	45,5	9079417

YHK model	UNIT		DIFFUSER		Packed unit Dimensions			
	Weights packed unit	Weights unpacked unit	Weights packed unit	Weights unpacked unit	A	B	C	D
	kg	kg	kg	kg	mm			
20-2 / 25-2	28	22	6	3	790	350	750	150
20-4 / 25-4	30	24						
40-2 / 40-4 / 40-6								
50-2 / 50-4 / 50-6								

YHK 65/95/110-2 / YHK 65/95/110-4 / YHK 95/110-6 (Version 800 x 800)

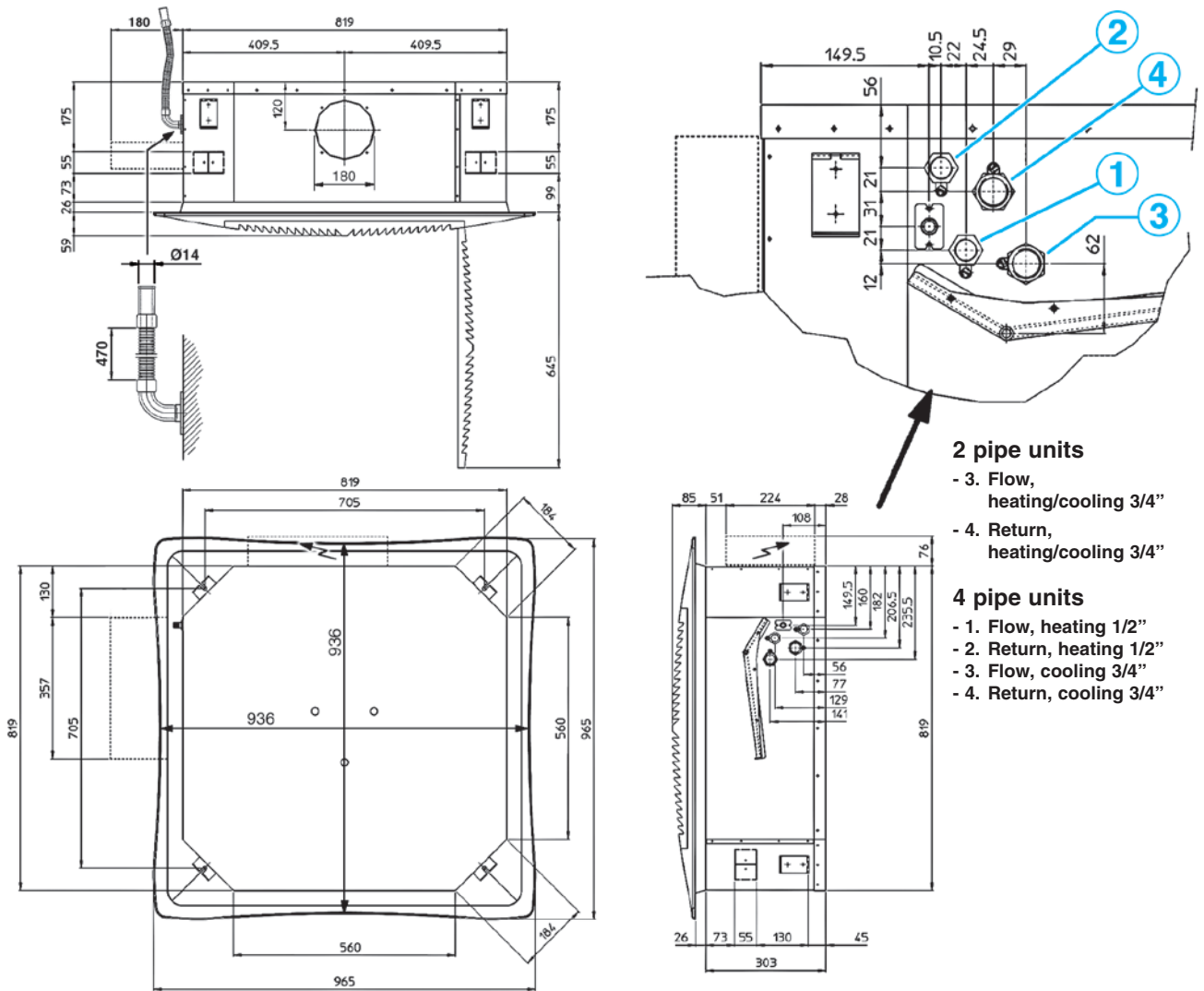

PACKED UNIT

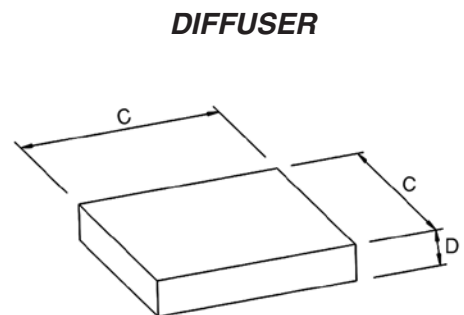
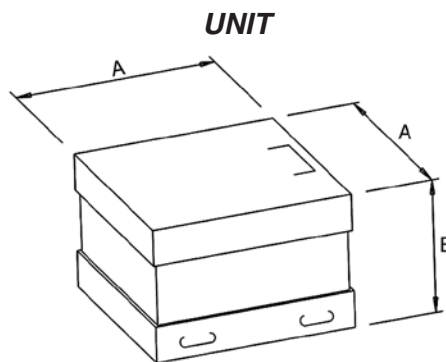

YHK model	UNIT		DIFFUSER		Packed unit Dimensions			
	Weights packed unit	Weights unpacked unit	Weights packed unit	Weights unpacked unit	A	B	C	D
					mm			
65-2	kg	kg	kg	kg	1050	400	1000	200
65-4	44	36	10	6				
95-2 / 95-4 / 95-6	47	39						
110-2 / 110-4 / 110-6								

The air throw indicated in the tables must only be considered the maximum value, as it may change significantly in relation to the dimensions of the room in which the appliance is installed and the positioning of the furniture in the room.

The useful throw **L** refers to the distance between the unit and the point where the air speed is 0.2 m/sec; if the louver has a gradient of 30° (recommended in cooling mode), the so-called “Coanda” effect will occur, illustrated in the first figure, while at a gradient of 45° (recommended in heating mode), there will be a downwards throw, as illustrated in the second figure.

With adjustable air diffusion louvers at 30°

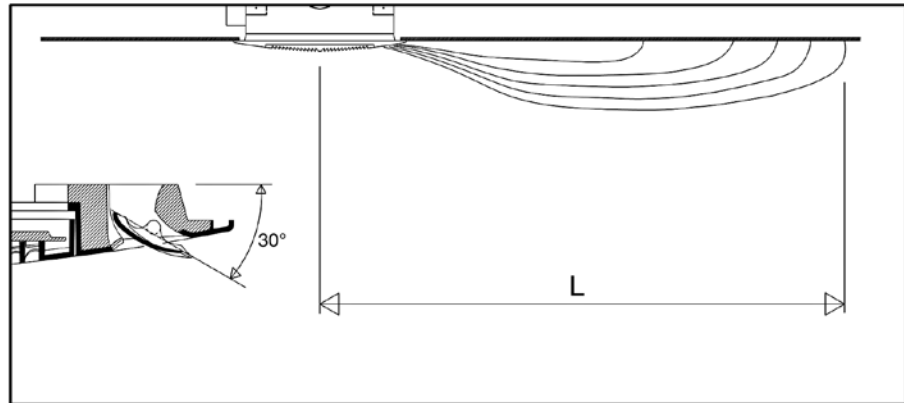

Model	YHK 20/25			YHK 40			YHK 50			YHK 65			YHK 95			YHK 110		
Speed	1	2	3	1	2	3	1	2	3	1	2	3	1	2	3	1	2	3
Air throw L m	3,0	3,5	3,8	3,0	3,8	4,5	3,5	4,2	5,0	3,2	3,7	4,3	3,4	4,0	5,0	3,4	4,6	5,5

With adjustable air diffusion louvers at 45°

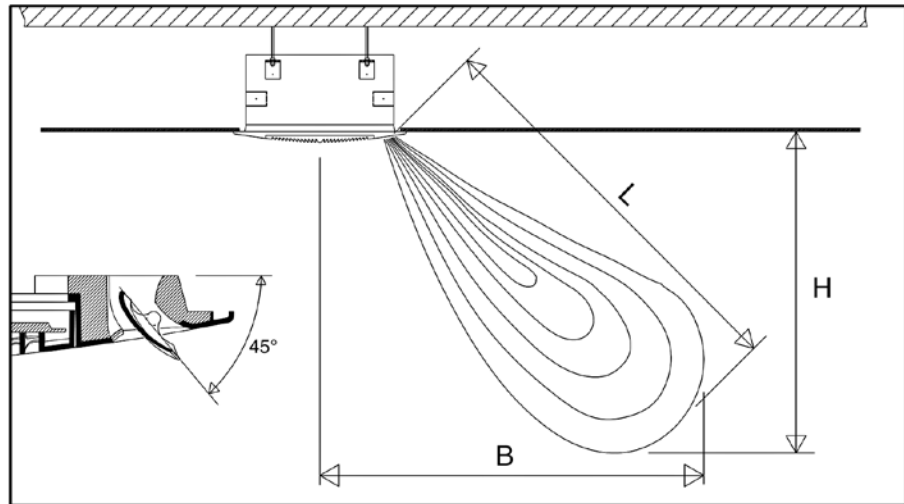

Model	YHK 20/25			YHK 40			YHK 50			YHK 65			YHK 95			YHK 110		
Speed	1	2	3	1	2	3	1	2	3	1	2	3	1	2	3	1	2	3
Air throw L m	3,3	3,9	4,2	3,3	4,2	4,8	3,9	4,5	5,2	3,5	4,1	4,8	3,8	4,6	5,4	3,8	5,1	5,8
Height H m	2,2	2,6	2,8	2,2	2,8	3,2	2,6	3,0	3,4	2,2	2,6	3,0	2,4	2,8	3,4	2,4	3,1	3,6
Distance B m	2,5	2,9	3,1	2,5	3,1	3,6	2,9	3,4	3,9	2,7	3,2	3,8	3,0	3,6	4,2	3,0	4,0	4,6

NOTE:

On heating it must be payed attention to rooms where the floor temperature is particularly low (for example less than 5°C).

In this situation the floor can cool the lower layer of air to a level that stop the uniform diffusion of the hot air coming from the unit, decreasing the throw figures shown in the table.

Fresh air supply - Fresh air connection

The cassette is fitted with inlets for fresh air to be mixed with return air inside the unit (for YHK 0-1-2-3 models only).

The fresh air flow is limited to 20% of the total fan coil air flow at medium speed and 100 m³/h for each treated air inlet.

The fresh air, suctioned by the "Fresh air connection FAD" (Fig. 3), is conveyed into the radial fan to be mixed with the return air (Fig. 4).

The units feature fresh air inlets on three corners (no inlets on the fourth corner because of the condensate pump inside the unit).

The fresh air inlets are designed for the insertion of standard 110 x 55 mm rectangular ducts.

The air duct is connected quickly and easily. After removing the blank and the insulation inside the unit, the mounting plate is rolled back and the air duct with its V-shaped section must be pushed into the unit (see Figures below). The duct is then fixed to the mounting plate.

Note: the fresh air must be filtered.

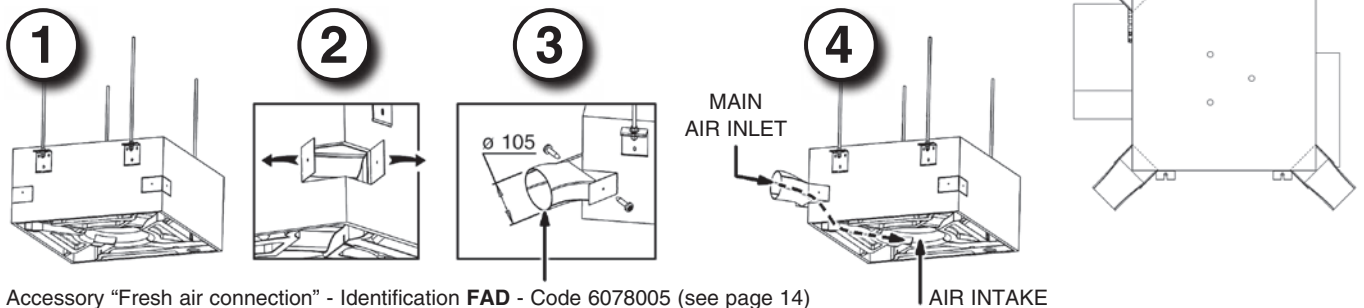
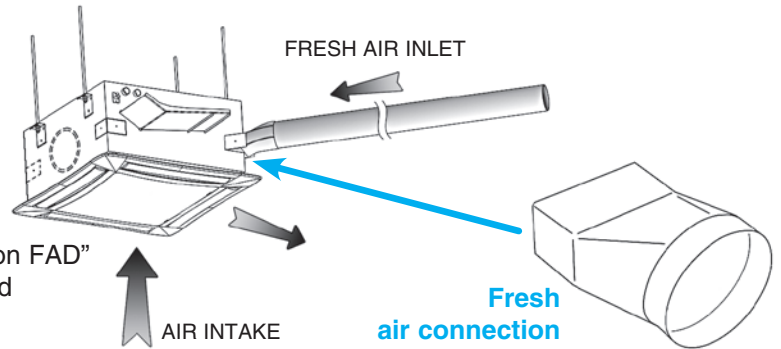

Accessory "Fresh air connection" - Identification **FAD** - Code 6078005 (see page 14)

Air distribution - Air distribution connection

Two air outlets are provided on the side of the unit for connection to separate supply air outlets.

They can be used to supply air from the fan coil unit to distant areas of a room or even to a different room.

The total air flow does not change.

The air flow at high speed depending on the air duct pressure drop is shown in the tables below.

Note: all air ducts must be insulated in order to avoid condensation.

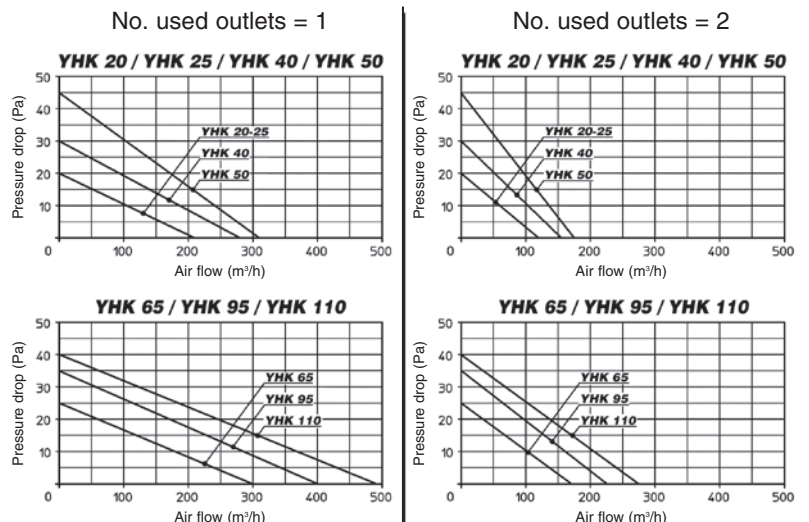
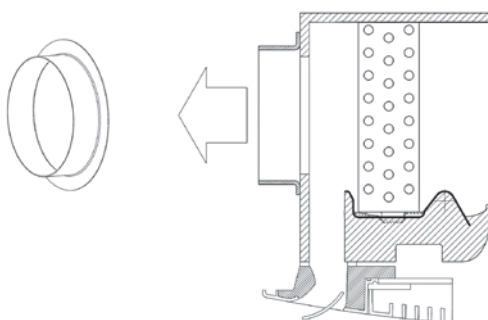
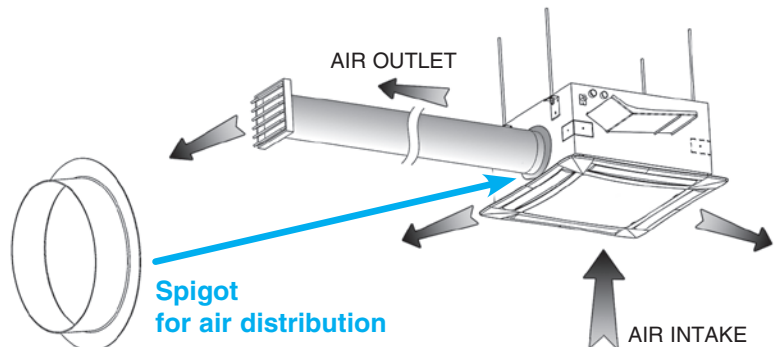

Fresh air connection

Only for YHK 0-1-2-3 models
(not suitable for OCA models with outer casing).

See page 13.

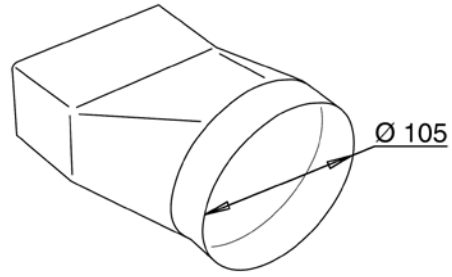

IDENTIFICATION	CODE
FAD	6078005

Air distribution connection

See page 13.

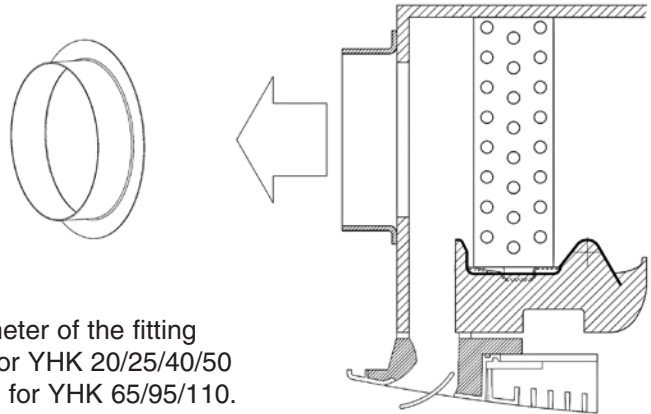

The diameter of the fitting is 150 mm for YHK 20/25/40/50 and 180 mm for YHK 65/95/110.

IDENTIFICATION	CODE
CDA 600	9079232
CDA 800	9079233

Fresh air kit

This is used to introduce fresh air into the environment directly through the diffuser. The kit includes a flow separator to be fitted inside the cassette, and a circular fitting for connection to the flexible system ducting. The flow of air is sent directly to just one of the outlet louvers, without passing through the coil.

The air flow of fresh air introduced into the environment depend on the inlet static pressure.

MODEL	YHK 20/25/40/50	YHK 65/95/110
IDENTIFICATION	FAK 600	FAK 800
CODE	9079230	9079231

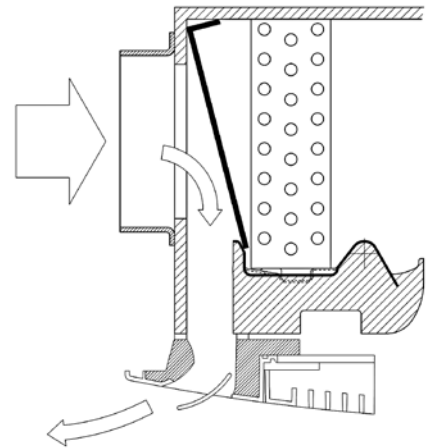

The diameter of the fitting is 150 mm for YHK 20/25/40/50 and 180 mm for YHK 65/95/110.

Correlation between flow-rate / static pressure

YHK 20/25/40/50		YHK 65/95/110	
m³/h	Pa	m³/h	Pa
80	3	160	3
120	8	200	8
160	15	300	15
200	25	400	25
240	36	500	36

Units with remote electric board

On request the YHK cassettes are available with electric control panel reachable from below and with the electric board that can be placed in a remote position. In this case the units are supplied with an electronic connecting control panel, fitted to the bottom side on the 4 smallest sizes and to the lateral side on the 3 biggest sizes.

The electronic control panel is connected to the fan motor, to the condensate pump and to the condensate level control.

A 6 m wire is also supplied with integral plug-in connections to connect the unit with the remote electric board that can be installed in a suitable and comfortable position, where the power and system connections can be made easily.

This feature is not available for units with electric heater or infrared remote control.

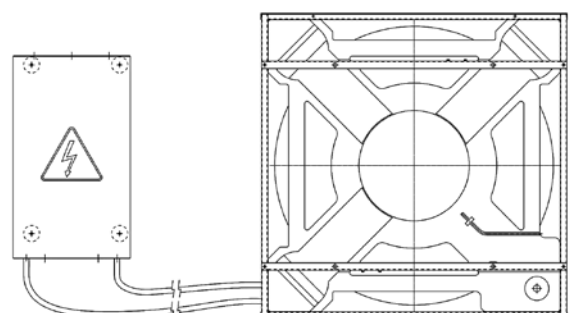

ON-OFF valves with thermoelectric actuator

VALVE WITH MICROMETRIC LOCKSHIELD VALVE

3 ways



YHK
20-2/20-4
25-2/25-4
40-2/40-4/40-6
50-2/50-4/50-6

YHK
65-2/65-4
95-2/95-4/95-6
110-2/110-4/110-6

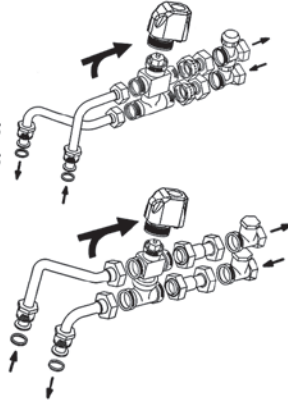

2 ways



YHK
20-2/20-4
25-2/25-4
40-2/40-4/40-6
50-2/50-4/50-6

YHK
65-2/65-4
95-2/95-4/95-6
110-2/110-4/110-6

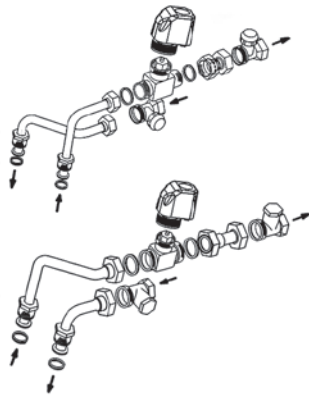

VALVE WITH SIMPLIFIED KIT

3 ways



YHK
20-2/20-4
25-2/25-4
40-2/40-4/40-6
50-2/50-4/50-6

YHK
65-2/65-4
95-2/95-4/95-6
110-2/110-4/110-6

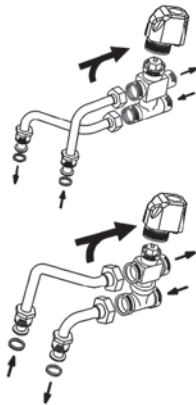

2 ways



YHK
20-2/20-4
25-2/25-4
40-2/40-4/40-6
50-2/50-4/50-6

YHK
65-2/65-4
95-2/95-4/95-6
110-2/110-4/110-6

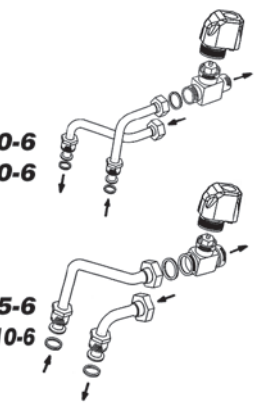

Technical data:

Rated pressure:	16 bar
Max. ambient temperature:	50 °C
Max. water flow temperature:	110 °C
Power:	230 V - 50/60 Hz
Rating:	3 VA
Protection:	IP 43
Travel time:	approx. 3 min.
Max. glycol content of water:	50%

Valves characteristics

Coil type	Model	2 way valves			3 way valves		
		K _{vs} m ³ /h	Δp _{max} kPa *	Valve ** connection	K _{vs} m ³ /h	Δp _{max} kPa *	Valve ** connection
Main	20/25/40/50-2	2,8	50	3/4"	2,5	50	3/4"
	20/25/40/50-4 40/50-6						
	65/95/110-2	5,2	60	1"	4,5	50	1"
Auxiliary	20/25/40/50-4 40/50-6	2,8	50	3/4"	2,5	50	3/4"
	65/95/110-4 95/110-6						

* maximum pressure difference for valve to close ** external thread, flat seal

Valves pressure drop

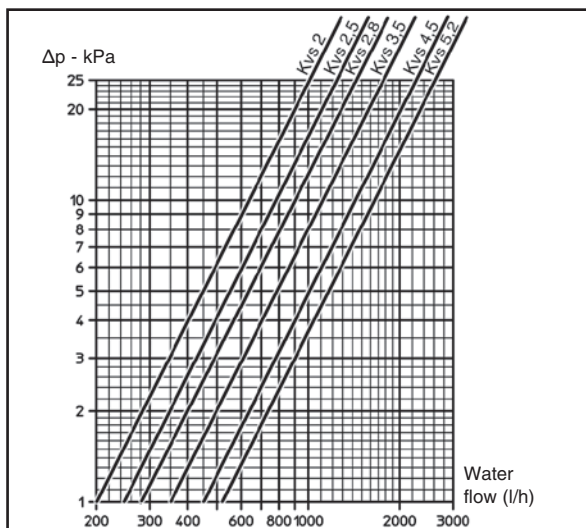

Valve set, 2 or 3 ways, ON-OFF, with thermoelectric actuator. The set includes connection pipes.

Note: The main coil lockshield valve connection is 1/2" female (Kvs 2) for YHK 20/25/40/50 sizes and 3/4" female (Kvs 3,5) for YHK 65/95/110 sizes, the auxiliary coil valve connection is 1/2" female (Kvs 2).

Note: The maximum pressure drop across the fully open valve should not exceed 25 kPa for cooling operation and 15 kPa for heating operation.

Balancing valves independent from the system pressure

- The balancing valve and a combined 2 way valve allow the regulation of the water flow value autonomously, regardless of the system pressure, and the control of the flow by using an ON/OFF electro-thermal actuator.
- The balancing valve allows you to balance the hydraulic system by supplying the required water flow, for each fan- coil, and to maintain it even under partial load conditions.
- A graduated ring nut placed under the valve allows you to set the flow rate value and also allows direct reading of the set value.



Valve operation logic

- “p1” is the valve inlet pressure.
- “p3” is the outlet pressure.
- “p2” is the diaphragm activation pressure, which allows differential pressure “p2” – “p3” to be maintained at a constant value, in order to guarantee the water to flow at the set value.

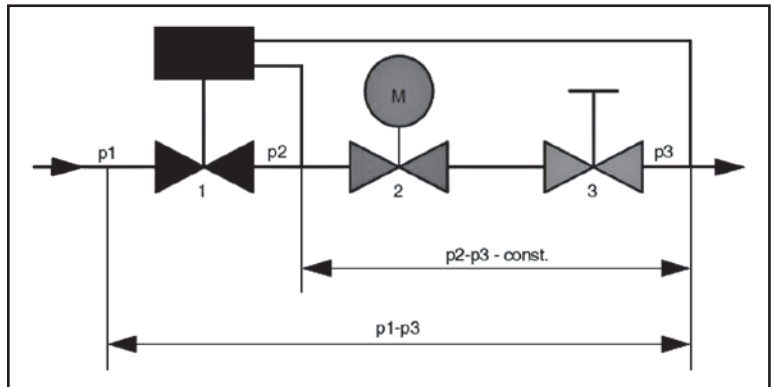

The minimum differential pressure “p1” – “p3”, required to guarantee the correct value of the set water flow rate, is indicated in the diagrams on page 17. This is an essential factor to size the system pressure drop and pump pressure head. The flow rate is kept at a constant value only if the valve pressure drop is higher than the indicated value.

Minimum operating differential pressure

The minimum differential pressure and the balancing valve pressure drop must be considered to size the system pumps.

Flow rate is constant if the pressure drop is higher than that indicated in the diagrams on page 17.

The following diagram shows an example of the flow rate trend according to the pressure drop and calibration required.

Example DN 15 Model

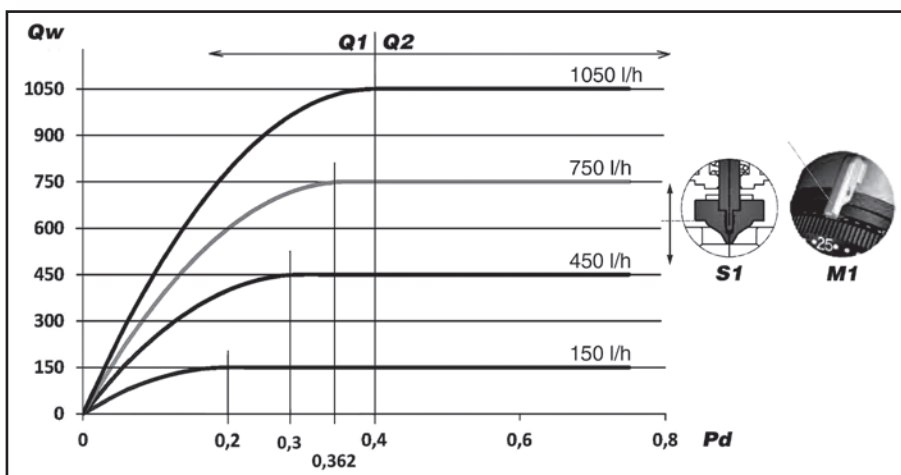

LEGEND:

Qw = Water flow rate (l/h)

Pd = Min. differential pressure “p1” – “p3” (bar)

Q1 = Area with inconstant water flow

Q2 = Area with constant water flow

S1 = Position of the adjustment valve plunger

M1 = Position of the knob

The valve upstream-downstream minimum differential pressure (“p1” – “p3”), which depends on the valve calibration value, must be exceeded to access the constant flow rate field.

DN 15 Model

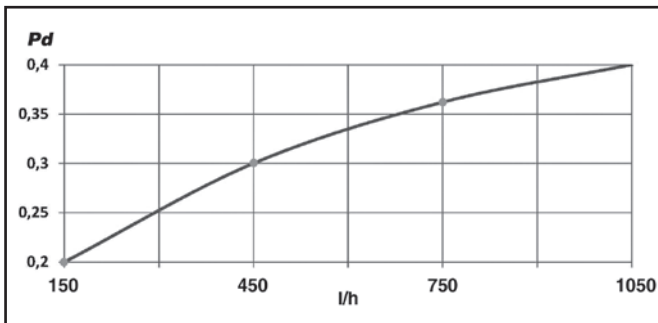

DN 20 Model

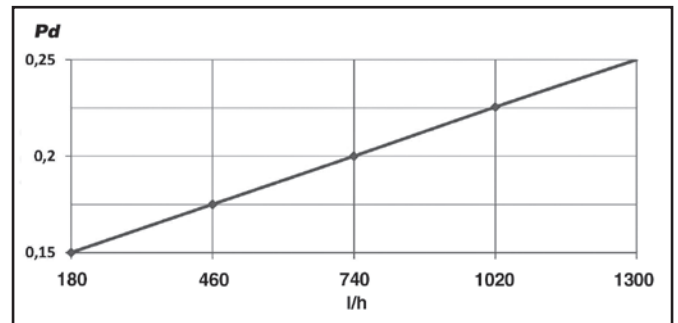

LEGEND:

Pd = Min. differential pressure “p1” – “p3” (bar)

E.g., when sizing the system pump, in which the **DN 15** valves will be installed and in which 450 l/h are constantly required for each device, consider a useful pressure of 0.3 bar (to compensate the pressure drop of the valve) for each balancing valve. Therefore, the pressure drop values produced by the system balancing valves must be summed and the pump must be sized to produce a pressure equal to or greater than the value obtained previously.

Benefits

- Reduced dimensions.
- Easy installation on 2 or 4 pipe devices.
- Pre-regulation of the nominal value set even with installed actuator.
- Easy display of the nominal value set. Nominal values are indicated in 10 l/h without any conversion.
- Guarantee of constant flow rate set even with partial loads.
- Pre-regulation can be blocked and leaded with the locking ring.

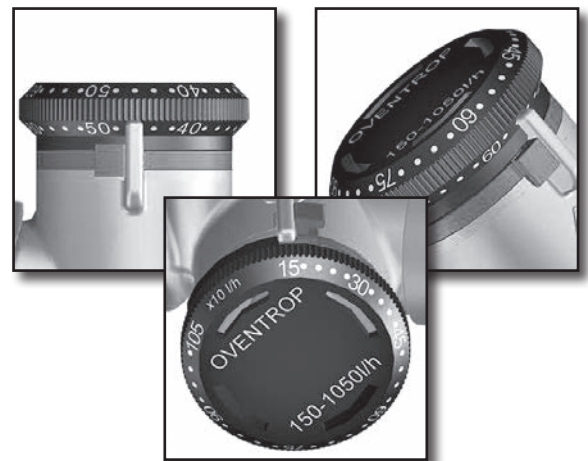

Technical features

DN MODEL	FLOW RATE RANGE (l/h)	Kvs
DN 15	150 – 1050	1,8
DN 20	180 – 1300	2,5

Operation limits of the balancing valves

- Maximum operating temperature 120°C
- Maximum operating pressure 16 bar
- Maximum % of water/glycol mixture 50%
- Minimum operating temperature -10°C
- Maximum differential pressure 4 bar

Balancing valves for main coil

2 way valve for main coil and assembly kit.

The valve is supplied equipped with 230 Volt electro-thermal actuator for the ON/OFF control.

YHK 20-25-40-50

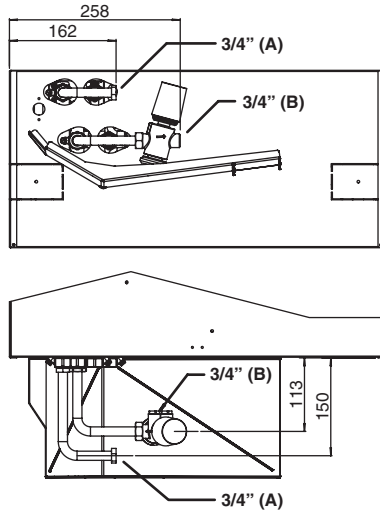

YHK 65

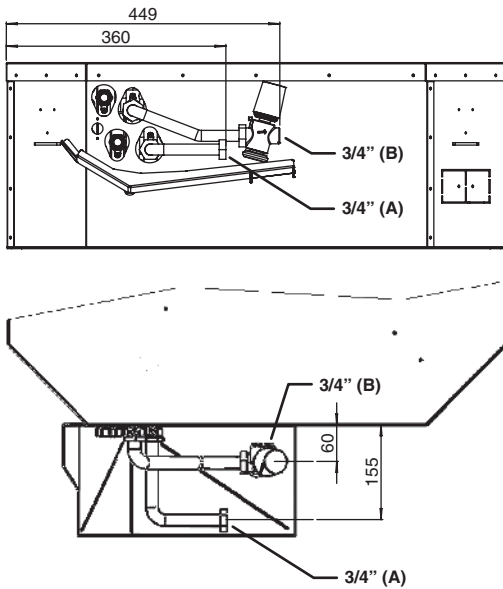

YHK 95-110

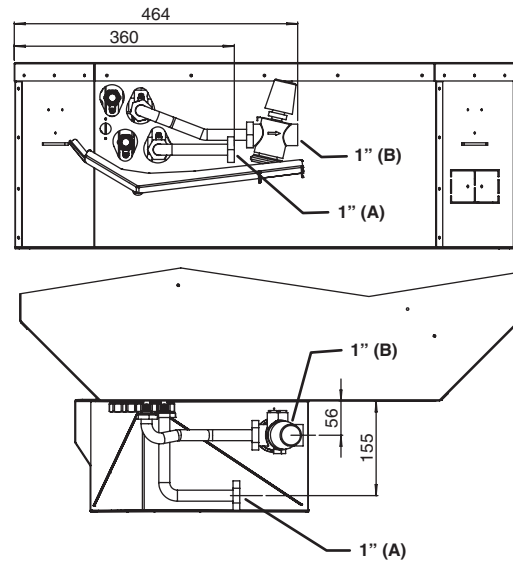

LEGEND

A = Water inlet - Female connection
 B = Water outlet - Male connection

MODEL	VALVE			FITTED		NOT FITTED	
	DN	Ø	Flow Rate Range (l/h)	CODE	IDENTIFICATION	CODE	IDENTIFICATION
20-25-40-50	15	3/4"	150 – 1050	9079771	V2OVSK6BPM 150-1050	9079761	V2OVSK6BPS 150-1050
65	15	3/4"	150 – 1050	9079791	V2OVSK8BPM 150-1050	9079781	V2OVSK8BPS 150-1050
95-110	20	1"	180 – 1300	9079792	V2OVSK8BPM 180-1300	9079782	V2OVSK8BPS 180-1300

Balancing valves for main and additional coil

2 way valve for additional coil and assembly kit.
The valve is supplied equipped with 230 Volt electro-thermal actuator for the ON/OFF control.

YHK 20-25-40-50

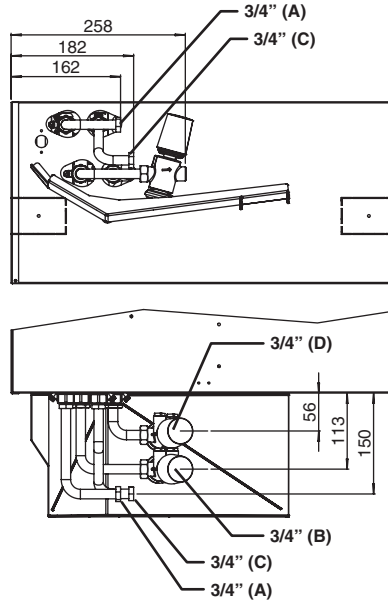

YHK 65

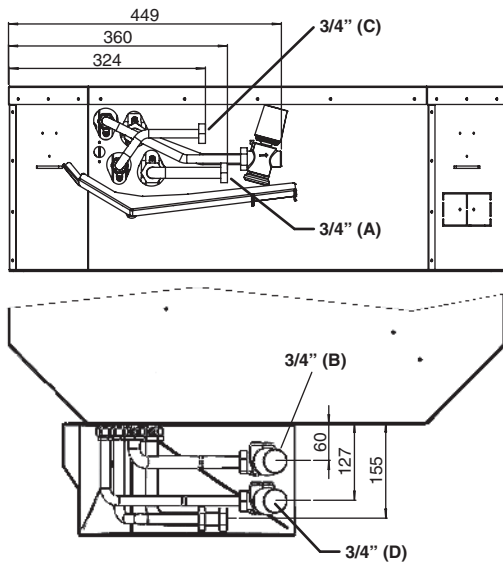

YHK 95-110

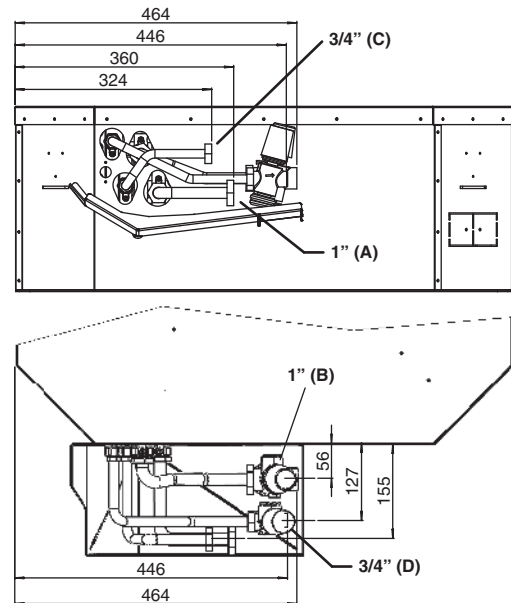

LEGEND

A = Water inlet (main coil) - Female connection
B = Water outlet (main coil) - Male connection

C = Water inlet (additional coil) - Female connection
D = Water outlet (additional coil) - Male connection

COIL	MODEL	VALVE			FITTED		NOT FITTED	
		DN	Ø	Flow Rate Range (l/h)	CODE	IDENTIFICATION	CODE	IDENTIFICATION
MAIN	20-25-40-50	15	3/4"	150 – 1050	9079771	V2OVSK6BPM 150-1050	9079761	V2OVSK6BPS 150-1050
	65	15	3/4"	150 – 1050	9079791	V2OVSK8BPM 150-1050	9079781	V2OVSK8BPS 150-1050
	95-110	20	1"	180 – 1300	9079792	V2OVSK8BPM 180-1300	9079782	V2OVSK8BPS 180-1300
ADDITIONAL	20-25-40-50	15	3/4"	150 – 1050	9079773	V2OVSK6BAM 150-1050	9079763	V2OVSK6BAS 150-1050
	65-95-110	15	3/4"	150 – 1050	9079793	V2OVSK8BAM 150-1050	9079783	V2OVSK8BAS 150-1050



If using the YHK Cassette fan coils with electronic controllers, the voltage values at the autotransformer terminals must be kept in consideration (transformer return voltages). These values may reach 500 Vac.

IDENTIFICATION	CODE
JWC-3V	9066642



Dimensions: 75x75x30 mm

- Manual 3 speed switch.
- Without thermostatic control.
- It can not control the valves.

IDENTIFICATION	CODE
JWC-T	9066630K



Dimensions: 135x86x31 mm

- ON-OFF switch.
- Manual 3 speed switch.
- Manual Summer/Winter switch.
- Electronic room thermostat for fan control (ON-OFF).
- Electronic room thermostat for valve control (ON-OFF) (the fan keeps working).
- It allows to control the low temperature cut-out thermostat (TMM).
- It allows to control the chilled water valve (ON-OFF) and the electric heater in the YHK-E version.
- Presence of a LED signal when the thermostat is on.

Control power absorption: 0,25 VA

IDENTIFICATION	CODE
JWC-TQR	9066631K



Dimensions: 135x86x31 mm

- ON-OFF switch.
- Manual 3 speed switch.
- Manual, automatic or centralized Summer/Winter switch.
- Electric heater/IAQ filter activation button.
- Electronic room thermostat for fan control (ON-OFF).
- Electronic room thermostat for valve control (ON-OFF) (the fan keeps working).
- Simultaneous thermostatic control of the valves and fan.
- It allows to control the low temperature cut-out thermostat (NTC).
- It allows to control the water valves (ON-OFF) and the electric heater managed as main heating element or as an integration element.
- Energy saving function.
- Presence of a LED signal when the thermostat is on.

Control power absorption: 1 VA

Wall electronic controls

IDENTIFICATION	CODE
JWC-AU	9066632K



Dimensions: 135x86x24 mm

The control must always be connected with JPF-AU power unit (fitted on the unit) or with JP-AU power unit (not fitted on the unit).

- ON-OFF push button.
- Manual or automatic 3 speed progressive push button.
- Manual, automatic or centralized Summer/Winter switch.
- Summer/Winter/Fan/Auto mode push button.
- Electric heater/IAQ filter activation button.
- Electronic room thermostat for fan control (ON-OFF).
- Electronic room thermostat for valve control (ON-OFF).
- Simultaneous thermostatic control of the valves and fan.
- It allows to control the low temperature cut-out thermostat (NTC).
- It allows to control the water valves (ON-OFF) and the electric heater managed as main heating element or as an integration element.
- Energy saving push button and presence of a LED signal when the thermostat is on.

N.B.: with 4 pipe installations and continuous chilled and hot water supply, it allows the automatic summer winter change-over in accordance to the room temperature (-1°C = Winter, +1°C = Summer, Neutral Zone 2°C).

Control power absorption: see the JP-AU power unit

IDENTIFICATION	CODE
JTM-B	9066331E



Dimensions: 110x72x25 mm

The control must always be connected with JPF-AU power unit (fitted on the unit) or with JP-AU power unit (not fitted on the unit).

Wall control with display that allows controlling one or more units in Master/Slave mode. The control is equipped with internal sensor to detect the room temperature, which can be defined as a priority compared to the return air sensor on the fan coil.

The JTM-B control features the following functions:

- Switch the unit ON and OFF.
- Temperature set.
- Manual, centralized or automatic Summer/Winter switch.
- Set the fan speed (low, medium, high or autofan).
- Set the operation mode (fan only, cooling, heating; auto for 4 pipe systems with mode selection depending on the air temperature).
- Possibility of use of the low temperature cut-out thermostat NTC mounted on the JP-AU power unit.
- It allows to control the chilled water valve (ON-OFF) and the electric heater in the YHK-E version.
- Time setting.
- Weekly ON/OFF program.

Control power absorption: see the JP-AU power unit

IDENTIFICATION	CODE
WM-503	9066676E



Dimensions: 68x52.2x58 mm

The WM-503 control is designed to be installed in a 503 wall box.

Easy to use, it is equipped with a large and efficient backlit LCD screen with 4 keys.

The thermostat is delivered with an external frame conceived for several combinations with adaptors and covers that make it suitable for more than 25 different frames belonging to various brands.

- Manual or automatic 3 speed switch.
- One single digital input to select: ON-OFF/SETPOINT reduction/Summer-Winter switch.
- Electronic room thermostat for fan control (ON/OFF).
- Electronic room thermostat for 1 water valve control (ON-OFF) (2 pipe system).
- Electronic room thermostat for 2 water valves control (ON-OFF) (4 pipe system).
- Simultaneous thermostatic control of the valves and fan.
- One single input to select: return air/water/change-over control probe.
- Possibility to use a low temperature cut-out thermostat NTC (optional).

Control power absorption: see the UP-503 power unit

IDENTIFICATION	CODE
T2T	9060174



Dimensions: 128x75x25 mm

2 pipes units only.

- ON-OFF switch.
- 3 speed switch.
- Manual Summer/Winter switch.
- Thermostatic control on the fan.
- Thermostatic control on the valve and continuous fan operation.
- Simultaneous thermostatic control of the valve and fan.

Control power absorption: 1,5 VA

IDENTIFICATION	CODE
SEL2M	9079109



- Speed switch (Slave).
- It allows to control up to 8 units with only one centralized wall control (1 speed switch for each unit).
- For controls JWC-T, JWC-TQR, and TMO-503-SV2.

DESCRIPTION	IDENTIFICATION	CODE
Power unit for JWC-AU and JTM-B remote control (fitted on the unit)	JPF-AU	9066641
Power unit for JWC-AU and JTM-B remote control (not fitted on the unit)	JP-AU	9066640



Power unit to be installed on the fan coil (fan coil interface).

- It controls the fan and the valves of the fan coil.
- It is connected to the electric supply.
- It receives the information required from the control.
- Possibility to use the low temperature cut-out thermostat (optional) for the T1 function which allows the return air control.
- Possibility to use the low temperature cut-out thermostat (optional) for the T2 function which controls the summer/winter switch.
- Possibility to use the low temperature cut-out thermostat (optional) for the T3 function as low temperature cut-out thermostat.
- It allows to control up to 10 units (1 master and 9 slaves).
- Max. Network length: 100 meters.
- Max cable length between control and first connected power unit: 20 meters.

Control power absorption: 2,3 VA

IDENTIFICATION	CODE
UP-503	9066677



Power unit to be installed on the fan coil (fan coil interface).

- It controls the fan and the valves of the fan coil.
- It is connected to the electric supply.
- It receives the information required from the control WM-503.
- It allows to control up to 5 units (1 master and 4 slaves).
- Max. Network length: 100 meters.
- Max cable length between control and first connected power unit: 20 meters.

Control power absorption: 2 VA

NTC low temperature cut-out thermostat

Suitable for wall controls only (not infra-red remote control). To be fitted between the coil fins; when connecting the control, the NTC probe cable must be separated from the power supply wires. To be used with JWC-TQR control and JP-AU power unit.

It stops the fan when the water temperature is lower than 28°C and it starts the fan when is higher than 33°C.

To use as:

- T1 function for the return air control.
- T2 function which controls the summer/winter switch.
- T3 function as low temperature cut-out thermostat.



IDENTIFICATION	CODE
NTC	3021090

TMM low temperature cut-out thermostat

To be installed in contact with the hot water circuit.

To be used only with JWC-T control.

For units working on heating only.

It stops the fan when the water temperature is lower than 30°C and it starts the fan when is higher than 38°C.



IDENTIFICATION	CODE
TMM	9053048

Change-Over CH 15-25

Suitable for wall controls only (not for infra-red remote control).

Automatic summer/winter switch

to be installed in contact with the water circuit.

For 2-tube installations only (not to be used with 2 way valve).

To be used only with JWC-TQR control.



IDENTIFICATION	CODE
CH 15-25	9053049

T2 sensor

T2 sensor to be placed on the water supply pipe upstream 3 way valves (not to be used with 2 way valve).

The T2 sensor must be used as described below:

- Change-Over for the automatic switch of the operating mode. If water temperature is lower than 20°C, cooling mode is set; on the other hand, if water temperature exceeds 30°C, heating mode is set.

To be used with JP-AU power unit.

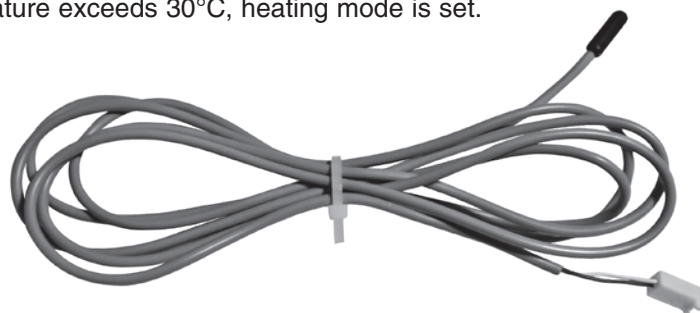

IDENTIFICATION	CODE
T2	9025310

All the **YHKY** units can be supplied in **MP version**. This version includes a wide range of controls, including the **infra-red remote control**, which allows managing one single unit or several units by using the Modbus RTU - RS 485 communication protocol.

Units can be managed according to the Master/Slave logic (up to 20 units) or by supervisory components.

The system consists in a **MP board** (*mounted on models YHKY-MP and YHKY-ECM-MP*) and a series of controls, such as the **JTM-B** wall control, the **RT03** infra-red remote control, the **PSM-DI** multifunction control and the **NET** supervisory program.



JTM-B wall control



PSM-DI multifunction control



RT03 infra-red remote control

PC

NET screenshot

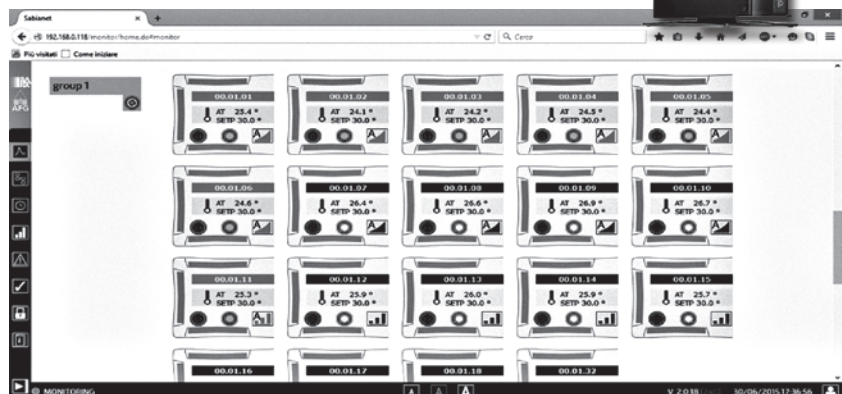

NET software

All the controls for the **ECM** version and their functions are described in detail from Page 46.

The Cassette 2 pipe models are available with electric resistance that is controlled in place of the heating coil valve. The electric resistance is controlled in place of the hot water valve and not as integration to it. The resistance is hermetically sealed and supplied inside the battery pipes and therefore can be only factory mounted. The electric resistances of the units are for single phase 230V supply. The Cassette includes no. 2 safety thermostats which intervene in case of internal over- heating, opening an auxiliary power relay (included in the shunt box) which stops the power supply to the resistances.

Model	YHK 25-2-E	YHK 40-2-E / 50-2-E	YHK 65-2-E / 95-2-E / 110-2-E
Emission	1500 Watt	2500 Watt	3000 Watt
Supply	230V ~	230V ~	230V ~
Number and Dia. of connecting wires	3 x 1,5 mm ²	3 x 2,5 mm ²	3 x 2,5 mm ²

Note: the cooling emission of the units is 95% of the emission in the tables of page 6.

Electric diagram

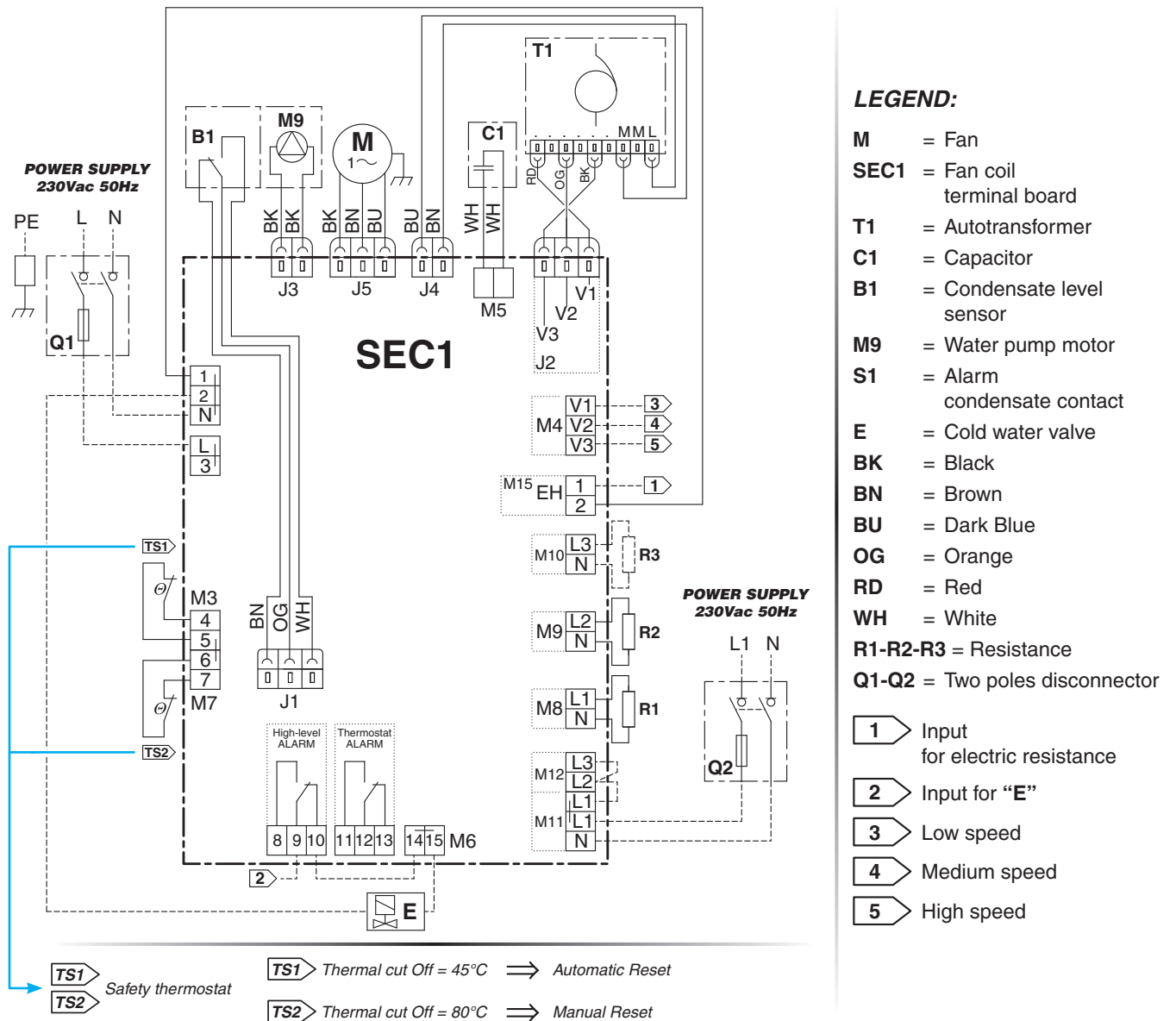

Cassette unit operating limits with electric coil

Max. ambient temperature for Cassette unit with electric coil in heating mode: 25°C

Introduction

The YHK-ECM series uses an innovative brushless synchronous permanent magnet electric motor controlled by an inverter card that is directly installed on the unit.

The air flow can be varied **continuously** with of a 1-10 V signal from JCI controls or by independent controllers (programmable controllers with a 1-10 V output).

The extreme efficiency, also at a low speed, makes possible a great reduction in electric consumption (**more than 75% less in comparison to a traditional motor**) with absorption values, under normal operating conditions, that are **no greater than 10 Watt** in the entire range.

The brushless motor is characterised by a constant synchronous speed, independently of the applied load, that depends only on the motor power supply frequency, which is modulated by the inverter. It consumes less because:

- The motor always works at its point of maximum efficiency.
- In the brushless motor, the rotor’s permanent magnets generate the magnetising power autonomously.
- The motor always operates at the synchronous speed, as a result there are no induced currents that reduce efficiency.

The main advantages are:

- Large reduction in energy consumption, thanks to an optimal response to the thermal load of the environment during every moment of the day.
- Operating silence at all rotation speeds.
- Ability to operate at any rotation speed.

MOTOR ABSORPTION

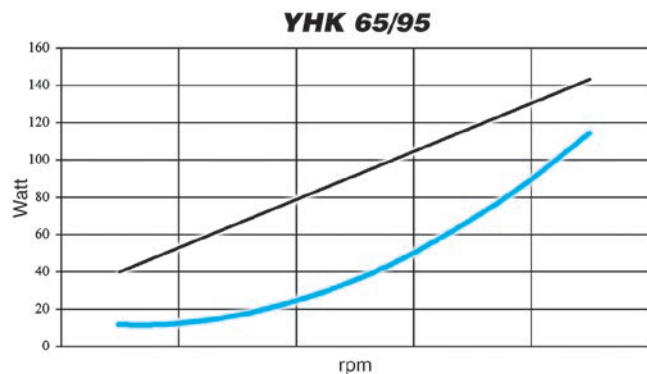
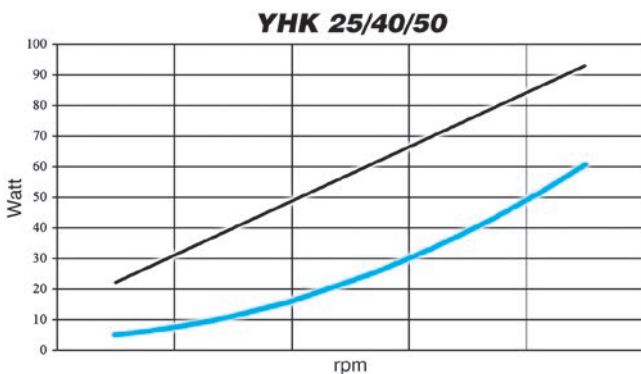

———— = **YHK** ————— = **YHK-ECM**

Main components

INTAKE GRID AND DISTRIBUTION OF THE AIR

Intake grids, frame and adjustable air distribution louvers on each side, made from ABS.

AKPA version: white ABS, RAL 9003

AKPB version: with intake grid, frame and louvers, choice of one colour only

AKPC version: with intake grid and louvers, choice of one colour, plus white ABS frame RAL 9003

AKPD version: with louvers, choice of one colour, while the grid and frame are made from ABS, RAL 9003

MD-600/MD-800 version: metal diffuser painted in RAL 9003 white colour with 600x600 dimension to perfectly fit into the false ceiling standard modules without overlapping parts.

CASING

Is made from galvanized steel with internal thermal insulation with polyolefin (PO) foam (class M1) and external anti-condensate lining.

CONTROL EQUIPMENT

YHKY-ECM version

It consists of the pump control circuit board and the inverter circuit board.

YHKY-ECM-MP version

It consists of the MP electronic board (that integrates pump control) and the inverter board.

FAN ASSEMBLY

The fan assembly, which is mounted on anti-vibrating supports, is extremely silent.

The radial fan has been designed to optimise performance, using wing profile blades with a shape that reduces turbulence, increasing efficiency and reducing noise.

The fans are connected to a three phase permanent magnet brushless electronic motor that is controlled with reconstructed current according to a BLAC sinusoidal wave.

The inverter board that controls the motor operation is powered by 230 Volt, single-phase and, with a switching system, it generates a three-phase frequency modulated, wave form power supply.

The electric power supply required for the machine is therefore single-phase with voltage of 230 - 240 V and frequency of 50 - 60 Hz.

COIL

Made of copper tubes with bonded aluminium fins for maximum transfer contact.

The coil has 2 or 3 rows for 2 pipe models and 2+1 rows for 4 pipe models (the heating row is on the inside part of the coil).

For 4 pipe systems two versions are available:

YHK 25-4 and YHK 65-4 supply an higher heating emission;

YHK 40-6, YHK 50-6, YHK 95-6 supply an higher cooling emission.

The heat exchanger is not suitable for use in corrosive atmosphere or in environments where aluminium may be subject to corrosion.

CONDENSATE COLLECTION TRAY

High density ABS polystyrene foam condensate tray, shaped in order to optimize the air diffusion, fire retardant rating B1 to DIN 4102.

AIR FILTER

Synthetic washable filter, easily removable.

CONDENSATE PUMP

Float switch centrifugal pump with 650 mm of maximum head, integral to the unit and wired to the control panel on the outside of the casing.

VALVE SET

Two or three way valves for ON/OFF operation, with pipe mounting kit and thermostatic actuator.

EUROVENT Certification

Technical features

2 pipe units. The following standard rating conditions are used:

COOLING

Entering air temperature +27°C d.b. +19°C w.b.
Water temperature +7°C E.W.T. +12°C L.W.T.

HEATING

Entering air temperature +20°C
Water temperature +45°C E.W.T. +40°C L.W.T.

MODEL		YHK-ECM 25-2					YHK-ECM 40-2					YHK-ECM 50-2				
		1	3	5	7,5	10	1	3	5	7,5	10	1	3	5	7,5	10
Speed		LOW		MED		HIGH	LOW		MED		HIGH	LOW		MED		HIGH
Air flow	m ³ /h	310	345	380	457	535	310	377	445	577	710	360	485	610	745	880
Cooling total emission (E)	kW	1,84	2,01	2,16	2,47	2,73	2,24	2,65	3,04	3,71	4,30	2,55	3,25	3,85	4,45	4,96
Cooling sensible emission (E)	kW	1,35	1,47	1,60	1,84	2,07	1,57	1,87	2,16	2,67	3,15	1,80	2,31	2,79	3,25	3,68
Heating (E)	kW	1,85	2,04	2,22	2,55	2,87	2,12	2,56	2,98	3,68	4,36	2,46	3,17	3,85	4,52	5,15
Dp Cooling (E)	kPa	4,9	5,8	6,6	8,4	10,1	4,6	6,3	11,0	11,6	15,1	5,9	9,1	12,4	16,2	19,7
Dp Heating (E)	kPa	4,3	5,1	5,9	7,6	9,4	3,6	5,1	6,6	9,7	13,2	4,7	7,5	10,6	14,1	17,8
Fan (E)	W	5	6,5	8	12	16	5	8	11	21	31	7	14	21	41,5	62
Sound power Lw (E)	dB(A)	33	36	39	43	47	33	38	43	48,5	54	37	43,5	50	55	60
Sound pressure Lp (*)	dB(A)	24	27	30	34	38	24	29	34	39,5	45	28	34,5	41	46	51
Water content	l	1,4					2,1					2,1				
Dimensions	mm	575 x 575 x 275														

MODEL		YHK-ECM 65-2					YHK-ECM 95-2				
		1	3	5	7,5	10	1	3	5	7,5	10
Speed		LOW		MED		HIGH	LOW		MED		HIGH
Air flow	m ³ /h	630	750	870	1017	1165	710	920	1130	1450	1770
Cooling total emission (E)	kW	4,20	4,70	5,13	5,76	6,30	5,28	6,54	7,69	9,28	10,69
Cooling sensible emission (E)	kW	3,02	3,39	3,75	4,23	4,69	3,68	4,62	5,50	6,71	7,83
Heating (E)	kW	4,27	4,78	5,30	6,02	6,70	4,90	6,18	7,34	9,00	10,56
Dp Cooling (E)	kPa	10,9	13,3	15,6	19,3	22,7	9,4	13,8	18,5	26,1	33,0
Dp Heating (E)	kPa	9,6	11,8	14,2	17,9	21,6	7,0	10,7	14,6	21,1	28,1
Fan (E)	W	10	13,5	17	25	33	10	21	32	70	108
Sound power Lw (E)	dB(A)	33	36	39	43,5	48	34	40,5	47	52	57
Sound pressure Lp (*)	dB(A)	24	27	30	34,5	39	25	31,5	38	43	48
Water content	l	3,0					4,0				
Dimensions	mm	820 x 820 x 303									

Condensate pump absorption: 10 W

(E) = Eurovent certified performance.

(*) = The sound pressure levels are 9 dB(A) lower than the sound power levels and apply to the reverberant field of a 100 m³ room and a reverberation time of 0.5 sec.

EUROVENT Certification

Technical features

4 pipe units. The following standard rating conditions are used:

COOLING

Entering air temperature +27°C d.b. +19°C w.b.
Water temperature +7°C E.W.T. +12°C L.W.T.

HEATING

Entering air temperature +20°C
Water temperature +65°C E.W.T. +55°C L.W.T.

MODEL		YHK-ECM 25-4					YHK-ECM 40-6					YHK-ECM 50-6				
		1	3	5	7,5	10	1	3	5	7,5	10	1	3	5	7,5	10
Speed		LOW		MED		HIGH	LOW		MED		HIGH	LOW		MED		HIGH
Air flow	m³/h	310	345	380	457	535	310	377	445	577	710	360	485	610	745	880
Cooling total emission (E)	kW	1,85	2,02	2,17	2,48	2,75	2,09	2,46	2,81	3,39	3,90	2,37	2,99	3,51	4,03	4,47
Cooling sensible emission (E)	kW	1,34	1,47	1,59	1,83	2,06	1,49	1,76	2,03	2,49	2,92	1,70	2,17	2,60	3,01	3,40
Heating (E)	kW	2,13	2,32	2,51	2,85	3,18	1,73	1,97	2,20	2,57	2,91	1,92	2,31	2,66	2,99	3,29
Dp Cooling (E)	kPa	4,6	5,4	6,2	7,9	9,5	3,3	4,4	5,6	7,9	10,3	4,1	6,3	8,4	10,9	13,1
Dp Heating (E)	kPa	4,6	5,3	6,1	7,7	9,4	2,6	3,3	4,1	5,4	6,7	3,2	4,4	5,7	7,1	8,4
Fan (E)	W	5	6,5	8	12	16	5	8	11	21	31	7	14	21	41,5	62
Sound power Lw (E)	dB(A)	33	36	39	43	47	33	38	43	48,5	54	37	43,5	50	55	60
Sound pressure Lp (*)	dB(A)	24	27	30	34	38	24	29	34	39,5	45	28	34,5	41	46	51
Cooling water content	l	1,4					1,7					1,7				
Heating water content	l	0,7					0,5					0,5				
Dimensions	mm	575 x 575 x 275														

MODEL		YHK-ECM 65-4					YHK-ECM 95-6				
		1	3	5	7,5	10	1	3	5	7,5	10
Speed		LOW		MED		HIGH	LOW		MED		HIGH
Air flow	m³/h	630	750	870	1017	1165	710	920	1130	1450	1770
Cooling total emission (E)	kW	4,29	4,81	5,29	5,92	6,48	4,97	6,13	7,14	8,56	9,76
Cooling sensible emission (E)	kW	3,07	3,46	3,82	4,32	4,80	3,51	4,37	5,17	6,27	7,29
Heating (E)	kW	5,41	6,04	6,65	7,46	8,24	4,58	5,47	6,27	7,36	8,33
Dp Cooling (E)	kPa	9,4	11,6	13,6	16,8	19,8	8,8	12,9	17,0	23,7	30,1
Dp Heating (E)	kPa	8,5	10,3	12,3	15,1	18,1	4,9	6,7	8,6	11,4	14,3
Fan (E)	W	10	13,5	17	25	33	10	21	32	70	108
Sound power Lw (E)	dB(A)	33	36	39	43,5	48	34	40,5	47	52	57
Sound pressure Lp (*)	dB(A)	24	27	30	34,5	39	25	31,5	38	43	48
Cooling water content	l	3,0					3,6				
Heating water content	l	1,4					1,1				
Dimensions	mm	820 x 820 x 303									

Condensate pump absorption: 10 W

(E) = Eurovent certified performance.

(*) = The sound pressure levels are 9 dB(A) lower than the sound power levels and apply to the reverberant field of a 100 m3 room and a reverberation time of 0.5 sec.

Emission

Cooling emission of 1 coil units (2 pipe installation)

Entering air temperature: +27°C d.b. – +19°C w.b.

ECM MOD.	Speed	Vdc	WT: 7/12 °C				WT: 8/13 °C			WT: 10/15 °C			WT: 12/17 °C		
			Qv m³/h	Qw l/h	Pc kW	Ps kW	Qw l/h	Pc kW	Ps kW	Qw l/h	Pc kW	Ps kW	Qw l/h	Pc kW	Ps kW
YHK 25-2	MAX	10	535	506	2,94	2,06	455	2,64	1,94	307	1,78	1,78	263	1,53	1,53
		7,5	457	455	2,64	1,84	409	2,38	1,73	323	1,88	1,52	234	1,36	1,36
	MED	5	380	399	2,32	1,60	360	2,09	1,50	284	1,65	1,32	206	1,20	1,20
		3	345	370	2,15	1,47	334	1,94	1,38	264	1,54	1,22	190	1,10	1,10
YHK 40-2	MAX	10	710	792	4,61	3,14	716	4,16	2,95	566	3,29	2,60	404	2,35	2,35
		7,5	577	681	3,96	2,67	617	3,59	2,51	490	2,85	2,20	379	2,20	1,93
	MED	5	445	559	3,25	2,16	508	2,95	2,03	403	2,35	1,78	312	1,81	1,56
		3	377	487	2,83	1,87	442	2,57	1,76	354	2,06	1,54	274	1,59	1,35
YHK 50-2	MAX	10	880	916	5,32	3,67	825	4,80	3,45	653	3,80	3,04	471	2,74	2,74
		7,5	745	817	4,75	3,24	738	4,29	3,05	585	3,40	2,69	417	2,43	2,43
	MED	5	610	710	4,13	2,79	643	3,74	2,62	510	2,97	2,31	394	2,29	2,02
		3	485	596	3,46	2,31	541	3,14	2,17	429	2,49	1,91	332	1,93	1,67
YHK 65-2	MAX	10	1165	1162	6,76	4,67	1049	6,10	4,40	826	4,80	3,88	599	3,48	3,48
		7,5	1017	1057	6,15	4,22	955	5,55	3,97	755	4,39	3,49	541	3,14	3,14
	MED	5	870	945	5,50	3,74	856	4,97	3,52	675	3,93	3,10	480	2,79	2,79
		3	750	861	5,01	3,39	780	4,54	3,19	619	3,60	2,80	438	2,55	2,55
YHK 95-2	MAX	10	1770	1962	11,41	7,81	1772	10,30	7,35	1410	8,20	6,48	1012	5,89	5,89
		7,5	1450	1702	9,90	6,70	1541	8,96	6,29	1227	7,14	5,55	951	5,53	4,87
	MED	5	1130	1415	8,22	5,49	1281	7,45	5,17	1026	5,96	4,54	791	4,60	3,98
		3	920	1200	6,98	4,61	1090	6,34	4,34	875	5,09	3,81	675	3,92	3,33
	MIN	1	710	968	5,63	3,68	881	5,12	3,46	710	4,13	3,04	550	3,20	2,66

Emission correction factors for different working conditions

Multiply the factors by the emission figures in the 7-12°C table above.

Note: the correction factors are indicative, as they are average values.

Water (°C)	Air (°C)	TOTAL EMISSION			Air (°C)	SENSIBLE EMISSION		
		25 - 18	26 - 18.5	28 - 20		25 - 18	26 - 18.5	28 - 20
7/12	K	0,82	0,89	1,11	K	0,90	0,94	1,06
10/15	K	0,56	0,63	0,82	K	0,72	0,78	0,90
14/18	K	0,35	0,41	0,52	K	0,50	0,58	0,72

LEGEND

- WT** = Water temperature
- Pc** = Cooling total emission
- Ps** = Cooling sensible emission
- Qw** = Water flow
- Speed** = Fan speed
- MAX** = High speed
- MED** = Medium speed
- MIN** = Low speed
- Vdc** = Inverter Power
- Qv** = Air flow

Emission

Heating emission of 1 coil units (2 pipe installation)

Entering air temperature: +20°C

				WT: 45/40 °C			WT: 50/40 °C		WT: 55/45 °C		WT: 60/50 °C		WT: 70/60 °C	
ECM MOD.	Speed	Vdc	Qv	Qw	Ph	Qw	Ph	Qw	Ph	Qw	Ph	Qw	Ph	
			<i>m³/h</i>	<i>l/h</i>	<i>kW</i>	<i>l/h</i>	<i>kW</i>	<i>l/h</i>	<i>kW</i>	<i>l/h</i>	<i>kW</i>	<i>l/h</i>	<i>kW</i>	
YHK 25-2	MAX	10	535	247	2,87	272	3,17	330	3,83	387	4,49	500	5,82	
		7,5	457	219	2,55	243	2,82	293	3,41	343	3,99	444	5,16	
	MED	5	380	191	2,22	213	2,48	257	2,99	300	3,49	387	4,51	
		3	345	176	2,04	196	2,28	236	2,74	276	3,21	355	4,13	
	MIN	1	310	159	1,85	178	2,07	214	2,49	250	2,91	322	3,75	
YHK 40-2	MAX	10	710	375	4,36	420	4,89	505	5,87	589	6,85	758	8,81	
		7,5	577	317	3,68	357	4,15	428	4,97	499	5,80	640	7,44	
	MED	5	445	256	2,98	290	3,38	347	4,04	404	4,70	517	6,01	
		3	377	220	2,56	251	2,92	300	3,48	348	4,05	444	5,16	
	MIN	1	310	183	2,12	209	2,43	249	2,90	289	3,36	368	4,28	
YHK 50-2	MAX	10	880	443	5,15	494	5,75	595	6,92	696	8,09	896	10,42	
		7,5	745	389	4,52	435	5,06	524	6,09	611	7,11	786	9,14	
	MED	5	610	331	3,85	373	4,34	448	5,20	522	6,07	670	7,79	
		3	485	273	3,17	309	3,59	370	4,30	430	5,01	551	6,41	
	MIN	1	360	212	2,46	241	2,81	288	3,35	335	3,89	427	4,96	
YHK 65-2	MAX	10	1165	576	6,70	642	7,47	774	9,00	904	10,51	1165	13,54	
		7,5	1017	517	6,02	579	6,73	696	8,10	813	9,46	1046	12,16	
	MED	5	870	456	5,30	512	5,95	615	7,15	717	8,34	922	10,72	
		3	750	411	4,78	463	5,38	555	6,45	647	7,52	830	9,65	
	MIN	1	630	367	4,27	415	4,82	497	5,78	578	6,72	741	8,61	
YHK 95-2	MAX	10	1770	908	10,56	1015	11,81	1222	14,21	1428	16,60	1837	21,37	
		7,5	1450	774	9,00	870	10,11	1045	12,15	1219	14,17	1565	18,20	
	MED	5	1130	631	7,34	713	8,29	854	9,93	994	11,56	1274	14,82	
		3	920	532	6,18	604	7,02	722	8,40	839	9,76	1073	12,47	
	MIN	1	710	421	4,90	481	5,60	574	6,67	666	7,74	849	9,87	

LEGEND

- WT** = Water temperature
- Ph** = Emission
- Qw** = Water flow
- Speed** = Fan speed
- MAX** = High speed
- MED** = Medium speed
- MIN** = Low speed
- Vdc** = Inverter Power
- Qv** = Air flow

**Emission of 4 pipe units
with standard and enhanced cooling coil**

Cooling emission of 2 coil units (4 pipe installation)

Entering air temperature: +27°C d.b. – +19°C w.b.

ECM MOD.	Speed	Vdc	Qv m³/h	WT: 7/12 °C			WT: 8/13 °C			WT: 10/15 °C			WT: 12/17 °C		
				Qw l/h	Pc kW	Ps kW	Qw l/h	Pc kW	Ps kW	Qw l/h	Pc kW	Ps kW	Qw l/h	Pc kW	Ps kW
YHK 25-4	MAX	10	535	508	2,95	2,05	458	2,66	1,93	305	1,77	1,77	261	1,52	1,52
		7,5	457	456	2,65	1,83	412	2,39	1,72	325	1,89	1,52	235	1,37	1,37
	MED	5	380	401	2,33	1,59	362	2,10	1,50	286	1,66	1,32	204	1,19	1,19
		3	345	371	2,16	1,47	336	1,95	1,38	265	1,54	1,21	188	1,09	1,09
	MIN	1	310	340	1,98	1,33	308	1,79	1,26	242	1,41	1,10	171	0,99	0,99
YHK 40-6	MAX	10	710	720	4,19	2,91	648	3,77	2,73	513	2,98	2,41	372	2,16	2,16
		7,5	577	623	3,62	2,49	562	3,27	2,34	446	2,59	2,06	319	1,85	1,85
	MED	5	445	516	3,00	2,03	467	2,71	1,91	369	2,15	1,68	261	1,52	1,52
		3	377	452	2,63	1,76	409	2,38	1,66	326	1,90	1,46	251	1,46	1,28
	MIN	1	310	383	2,23	1,48	347	2,02	1,39	277	1,61	1,22	214	1,24	1,07
YHK 50-6	MAX	10	880	826	4,80	3,38	742	4,31	3,18	586	3,41	2,81	431	2,51	2,51
		7,5	745	742	4,31	3,00	667	3,88	2,82	527	3,06	2,49	384	2,23	2,23
	MED	5	610	649	3,77	2,60	585	3,40	2,44	462	2,69	2,15	333	1,94	1,94
		3	485	548	3,19	2,17	496	2,88	2,04	393	2,28	1,79	278	1,62	1,62
	MIN	1	360	436	2,54	1,70	395	2,30	1,60	314	1,83	1,40	243	1,41	1,23
YHK 65-4	MAX	10	1165	1196	6,95	4,79	1080	6,28	4,50	851	4,95	3,96	613	3,56	3,56
		7,5	1017	1086	6,31	4,31	982	5,71	4,06	775	4,51	3,57	553	3,21	3,21
	MED	5	870	969	5,64	3,82	878	5,10	3,59	697	4,05	3,16	495	2,88	2,88
		3	750	882	5,13	3,45	800	4,65	3,25	634	3,69	2,86	447	2,60	2,60
	MIN	1	630	790	4,59	3,07	717	4,17	2,89	567	3,30	2,54	439	2,55	2,22
YHK 95-6	MAX	10	1770	1801	10,47	7,26	1623	9,44	6,83	1286	7,48	6,03	933	5,42	5,42
		7,5	1450	1571	9,14	6,25	1419	8,25	5,88	1123	6,53	5,18	805	4,68	4,68
	MED	5	1130	1315	7,65	5,17	1191	6,93	4,86	942	5,48	4,27	731	4,25	3,74
		3	920	1123	6,53	4,36	1019	5,93	4,10	810	4,71	3,60	625	3,63	3,16
	MIN	1	710	913	5,31	3,51	831	4,83	3,30	664	3,86	2,90	514	2,99	2,53

Emission correction factors for different working conditions

Multiply the factors by the emission figures in the 7-12°C table above.

Note: the correction factors are indicative, as they are average values.

Water (°C)	Air (°C)	TOTAL EMISSION			Air (°C)	SENSIBLE EMISSION		
		25 - 18	26 - 18.5	28 - 20		25 - 18	26 - 18.5	28 - 20
7/12	K	0,82	0,89	1,11	K	0,90	0,94	1,06
10/15	K	0,56	0,63	0,82	K	0,72	0,78	0,90
14/18	K	0,35	0,41	0,52	K	0,50	0,58	0,72

LEGEND

- WT** = Water temperature
- Pc** = Cooling total emission
- Ps** = Cooling sensible emission
- Qw** = Water flow
- Speed** = Fan speed
- MAX** = High speed
- MED** = Medium speed
- MIN** = Low speed
- Vdc** = Inverter Power
- Qv** = Air flow

**Emission of 4 pipe units
with standard and enhanced cooling coil**

Heating emission of 2 coil units (4 pipe installation)

Entering air temperature: +20°C

ECM MOD.	Speed	Vdc	Qv m³/h	WT: 45/40 °C		WT: 50/40 °C		WT: 55/45 °C		WT: 60/50 °C		WT: 70/60 °C	
				Qw l/h	Ph kW	Qw l/h	Ph kW	Qw l/h	Ph kW	Qw l/h	Ph kW	Qw l/h	Ph kW
YHK 25-4	MAX	10	535	153	1,78	161	1,87	198	2,30	236	2,74	311	3,62
		7,5	457	137	1,59	144	1,68	178	2,07	212	2,46	279	3,24
	MED	5	380	120	1,40	127	1,48	156	1,82	186	2,16	245	2,85
		3	345	112	1,30	118	1,37	145	1,69	172	2,01	227	2,64
	MIN	1	310	103	1,19	108	1,26	133	1,55	158	1,84	209	2,43
YHK 40-6	MAX	10	710	139	1,62	139	1,61	176	2,04	213	2,48	288	3,35
		7,5	577	123	1,43	123	1,43	156	1,81	189	2,19	254	2,96
	MED	5	445	105	1,23	106	1,23	133	1,55	161	1,87	217	2,53
		3	377	95	1,10	95	1,11	120	1,39	145	1,68	195	2,27
	MIN	1	310	83	0,96	83	0,97	105	1,22	127	1,47	170	1,98
YHK 50-6	MAX	10	880	158	1,83	156	1,82	198	2,31	241	2,80	326	3,79
		7,5	745	143	1,67	142	1,66	181	2,10	219	2,54	296	3,44
	MED	5	610	127	1,48	127	1,48	161	1,87	195	2,27	263	3,06
		3	485	111	1,29	111	1,29	140	1,63	170	1,97	229	2,66
	MIN	1	360	92	1,07	93	1,08	117	1,36	141	1,64	189	2,20
YHK 65-4	MAX	10	1165	396	4,61	421	4,90	517	6,01	613	7,13	805	9,36
		7,5	1017	359	4,17	382	4,44	468	5,45	555	6,46	729	8,48
	MED	5	870	320	3,72	340	3,96	417	4,85	494	5,75	649	7,54
		3	750	291	3,38	310	3,60	380	4,41	450	5,23	590	6,86
	MIN	1	630	260	3,03	278	3,23	340	3,96	403	4,68	528	6,14
YHK 95-6	MAX	10	1770	400	4,65	413	4,80	514	5,97	615	7,15	818	9,51
		7,5	1450	353	4,11	365	4,25	454	5,28	543	6,32	722	8,40
	MED	5	1130	301	3,50	312	3,63	388	4,51	464	5,39	616	7,16
		3	920	263	3,06	273	3,18	339	3,94	405	4,70	537	6,24
	MIN	1	710	220	2,56	229	2,67	284	3,30	339	3,94	449	5,22

LEGEND

- WT = Water temperature
- Ph = Emission
- Qw = Water flow
- Speed = Fan speed
- MAX = High speed
- MED = Medium speed
- MIN = Low speed
- Vdc = Inverter Power
- Qv = Air flow

Water side pressure drop

2 pipe installation

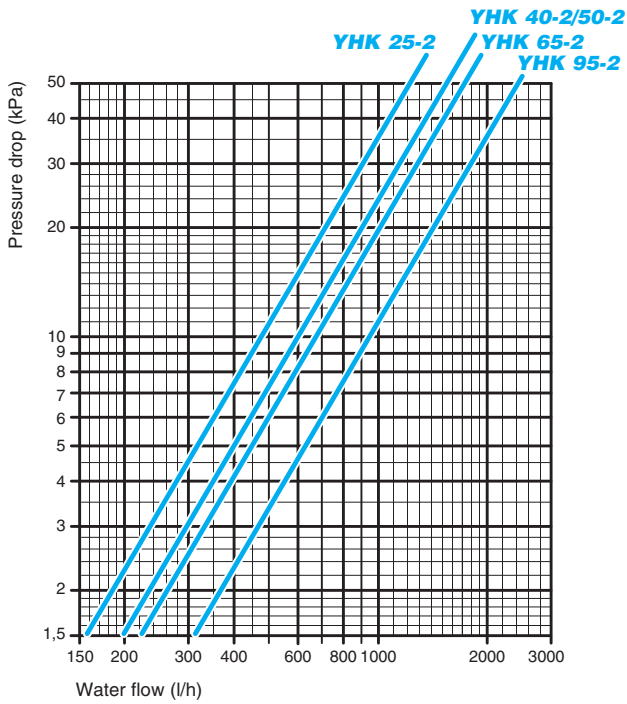

The water pressure drop figures refer to a mean water temperature of **10°C**; for different temperatures, multiply the pressure drop figures by the correction factors **K**.

°C	20	30	40	50	60	70	80
K	0,94	0,90	0,86	0,82	0,78	0,74	0,70

4 pipe installation

Pressure drop for cooling coil

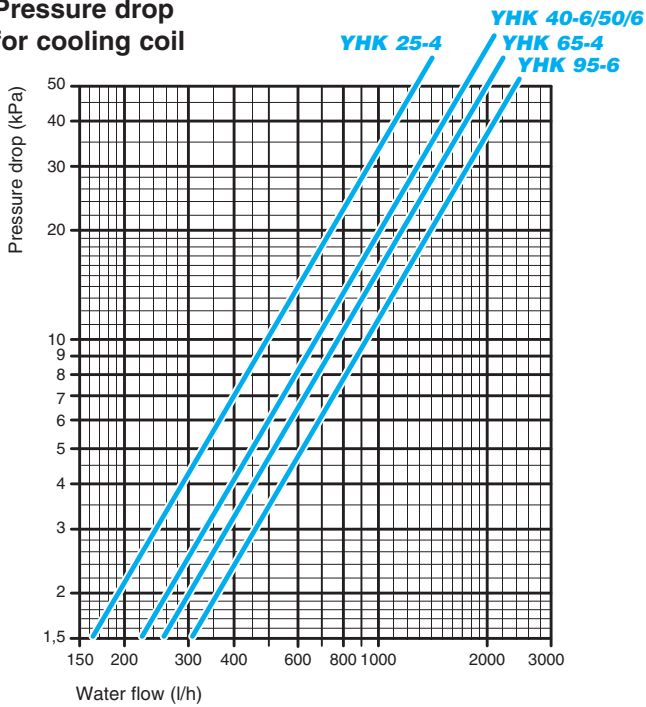

The water pressure drop figures refer to a mean water temperature of **10°C**; for different temperatures, multiply the pressure drop figures by the correction factors **K**.

°C	20	30	40	50	60	70	80
K	0,94	0,90	0,86	0,82	0,78	0,74	0,70

Pressure drop for heating coil

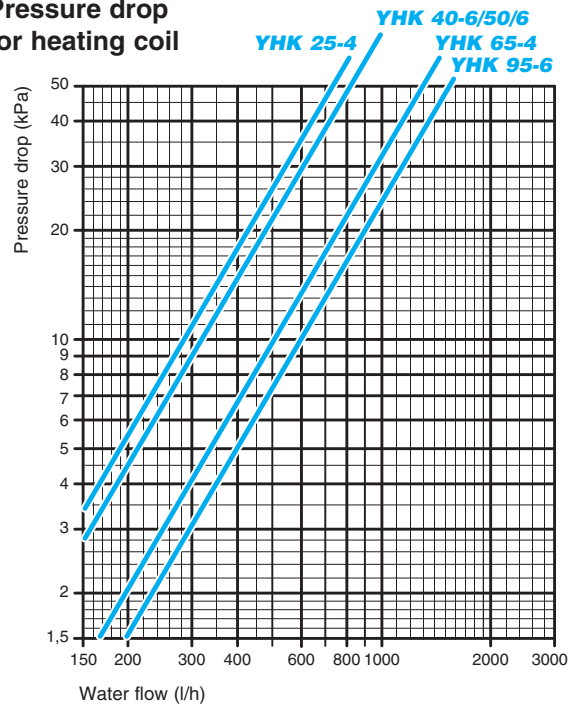

The water pressure drop figures refer to a mean water temperature of **60°C**; for different temperatures, multiply the pressure drop figures by the correction factors **K**.

°C	40	50	70	80
K	1,12	1,06	0,94	0,88

Working conditions

Water flow	MAX. working pressure: 8 bars	MIN. entering water temperature: +5°C
		MAX. entering water temperature: +80°C
Air flow	Suitable relative humidity: 15-75%	MIN. entering air temperature: +6°C
		MAX. entering air temperature: +40°C
Supply	Single phase 230V / 50Hz	
Installation	MAX. height: see table on page 12	



MD-600 metal diffuser

Dimensions and weights

YHK-ECM 25-2 / 25-4 / 40-2 / 40-6 / 50-2 / 50-6 (Version 600 x 600)

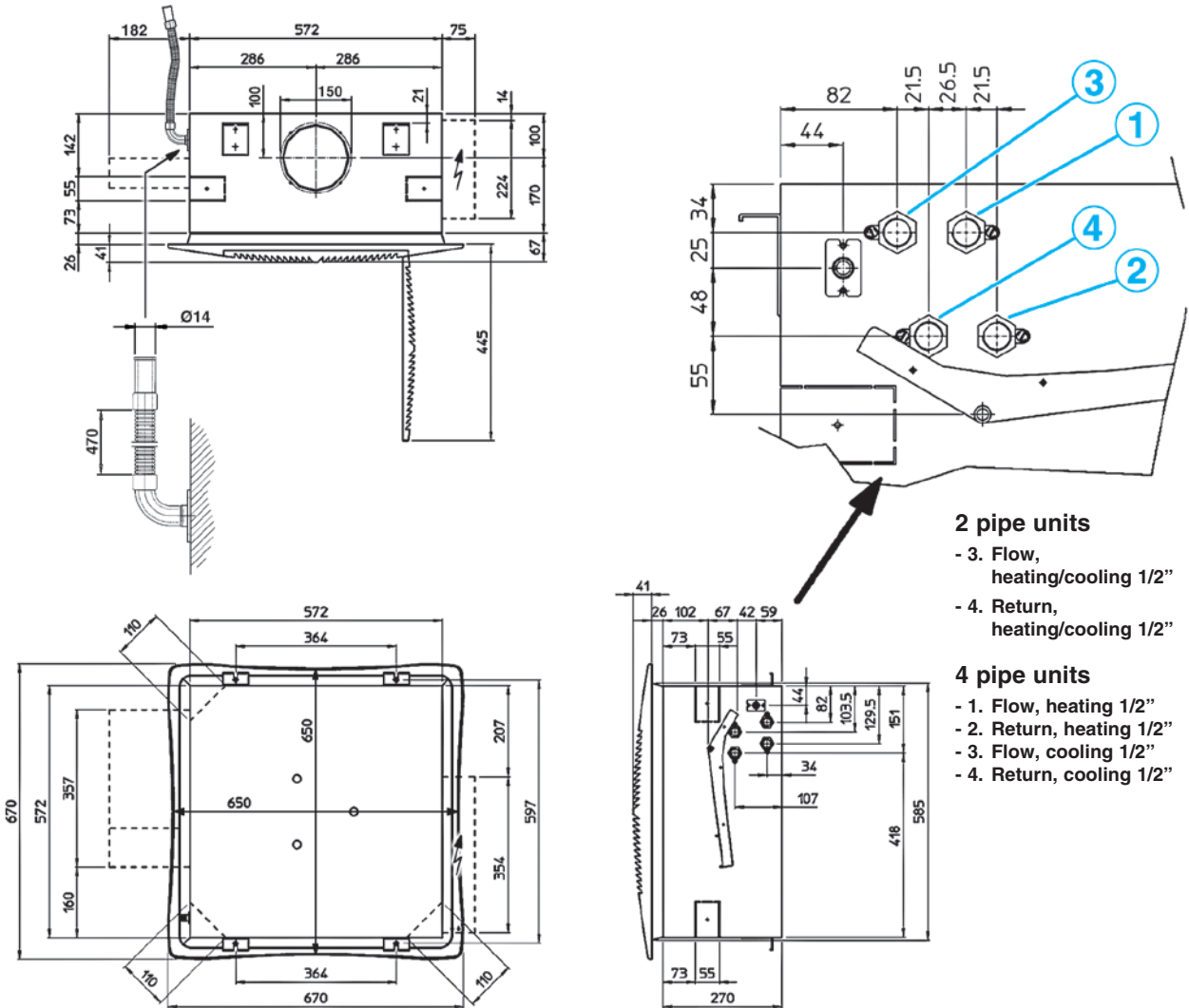

MD-600/MD-800 METAL DIFFUSER

(RS receiver, Code 9066338, for MD-600/MD-800 metal diffuser for MP units)

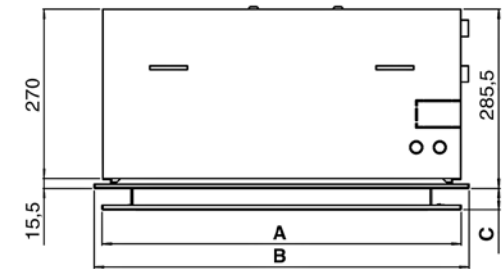
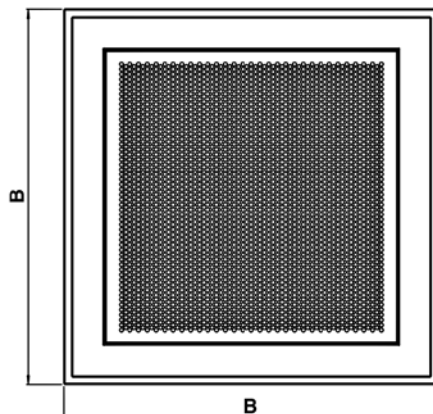

Size	A	B	C	Code
MD-600	574	599	34,5	9079420
MD-800	845	880	45,5	9079417

ECM Model	UNIT		DIFFUSER		Packed unit Dimensions			
	Weights packed unit	Weights unpacked unit	Weights packed unit	Weights unpacked unit	A	B	C	D
	kg	kg	kg	kg	mm			
YHK 25-2	28	22	6	3	790	350	750	150
YHK 25-4	30	24						
YHK 40-2 / 40-6								
YHK 50-2 / 50-6								

Dimensions and weights

YHK-ECM 65-2 / 65-4 / 95-2 / 95-6 (Version 800 x 800)

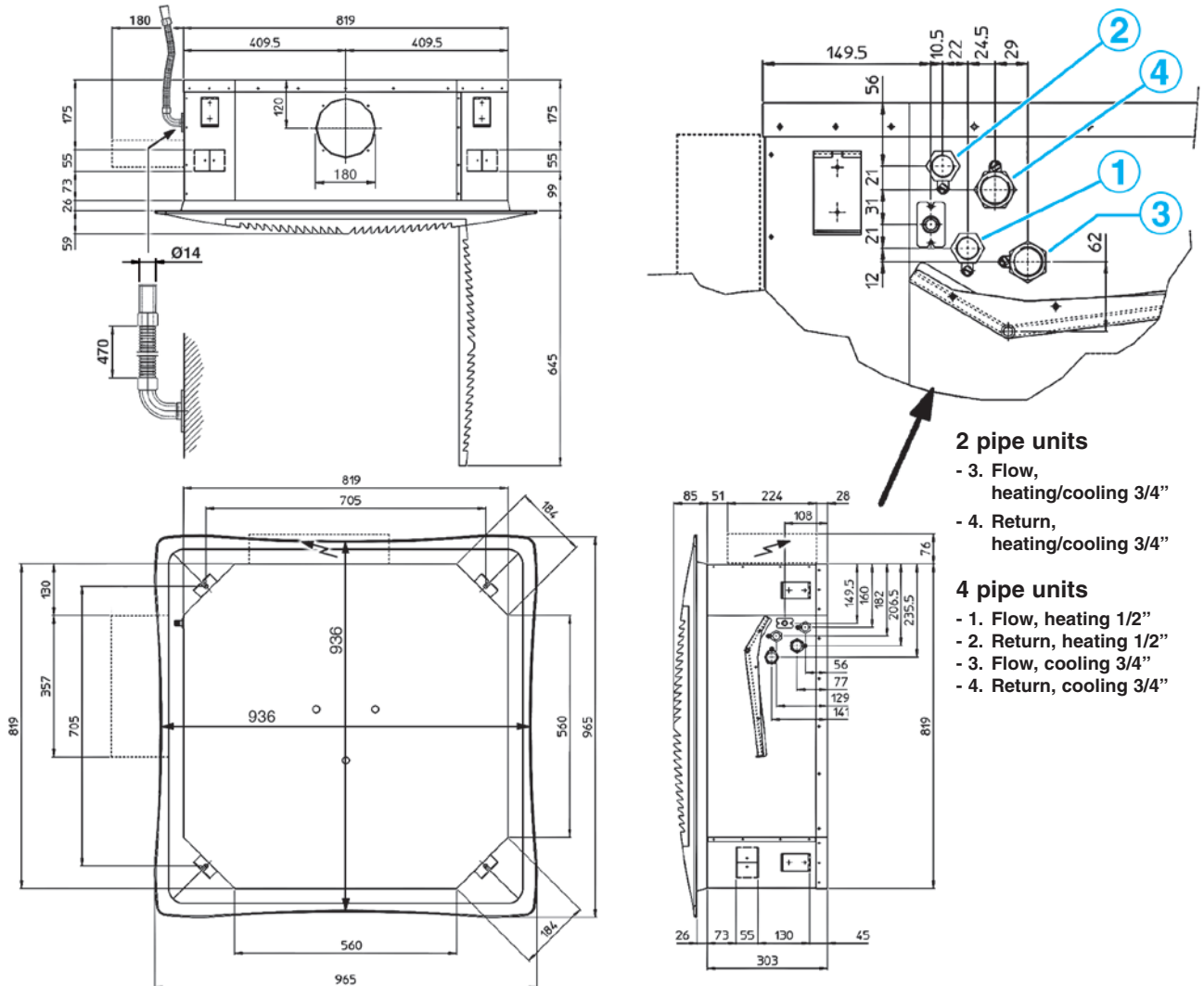

PACKED UNIT

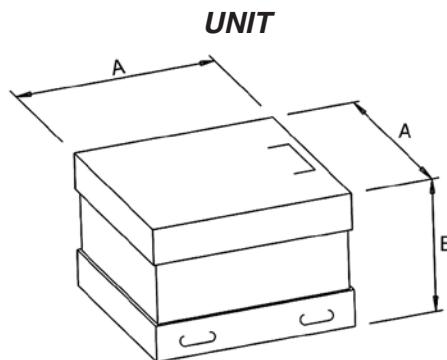

DIFFUSER

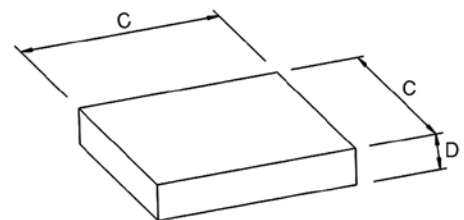

ECM Model	UNIT		DIFFUSER		Packed unit Dimensions			
	Weights packed unit	Weights unpacked unit	Weights packed unit	Weights unpacked unit	A	B	C	D
	kg	kg	kg	kg	mm			
YHK 65-2	44	36	10	6	1050	400	1000	200
YHK 65-4	47	39						
YHK 95-2 / 95-4								

Air throw

The air throw indicated in the tables must only be considered the maximum value, as it may change significantly in relation to the dimensions of the room in which the appliance is installed and the positioning of the furniture in the room.

The useful throw **L** refers to the distance between the unit and the point where the air speed is 0.2 m/sec; if the louver has a gradient of 30° (recommended in cooling mode), the so-called “Coanda” effect will occur, illustrated in the first figure, while at a gradient of 45° (recommended in heating mode), there will be a downwards throw, as illustrated in the second figure.

With adjustable air diffusion louvers at 30°

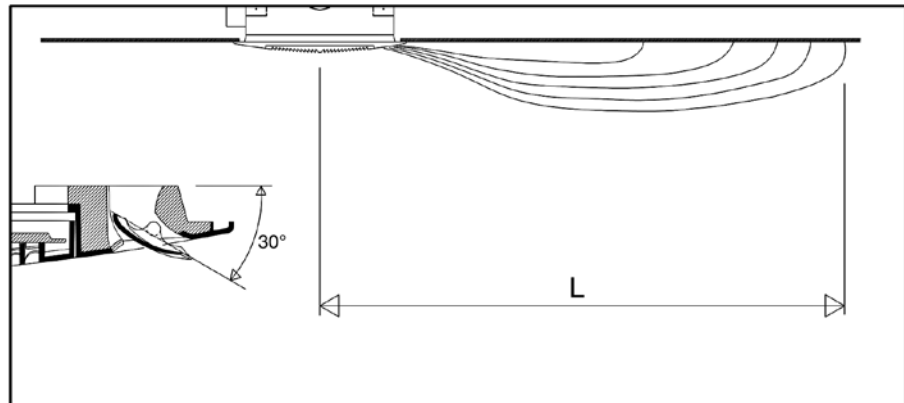

ECM Model		YHK 25			YHK 40			YHK 50			YHK 65			YHK 95		
Speed		1	2	3	1	2	3	1	2	3	1	2	3	1	2	3
Air throw	L m	3,0	3,5	3,8	3,0	3,8	4,5	3,5	4,2	5,0	3,2	3,7	4,3	3,4	4,0	5,0

With adjustable air diffusion louvers at 45°

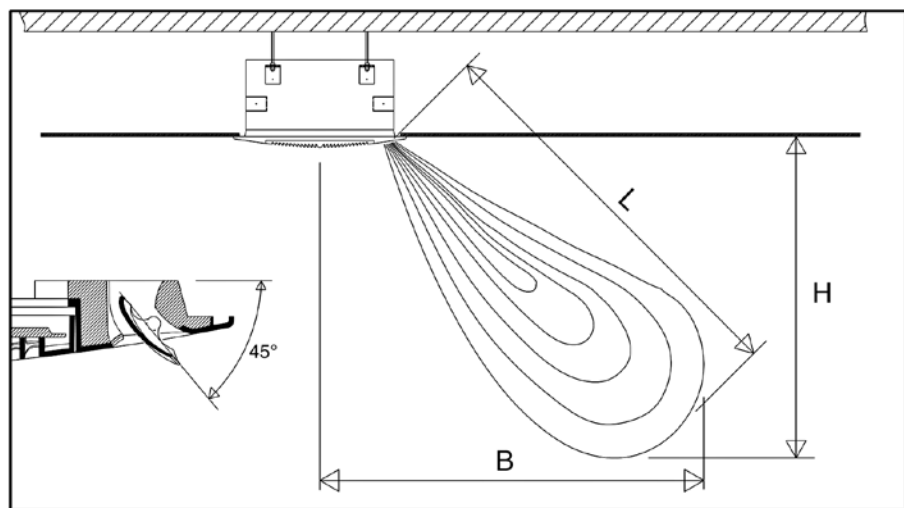

ECM Model		YHK 25			YHK 40			YHK 50			YHK 65			YHK 95		
Speed		1	2	3	1	2	3	1	2	3	1	2	3	1	2	3
Air throw	L m	3,3	3,9	4,2	3,3	4,2	4,8	3,9	4,5	5,2	3,5	4,1	4,8	3,8	4,6	5,4
Height	H m	2,2	2,6	2,8	2,2	2,8	3,2	2,6	3,0	3,4	2,2	2,6	3,0	2,4	2,8	3,4
Distance	B m	2,5	2,9	3,1	2,5	3,1	3,6	2,9	3,4	3,9	2,7	3,2	3,8	3,0	3,6	4,2

NOTE: On heating it must be payed attention to rooms where the floor temperature is particularly low (for example less than 5°C).

In this situation the floor can cool the lower layer of air to a level that stop the uniform diffusion of the hot air coming from the unit, decreasing the throw figures shown in the table.

Accessories

Fresh air connection

Only for YHK 1-2-3 models
(not suitable for OCA models with outer casing).

See page 13.

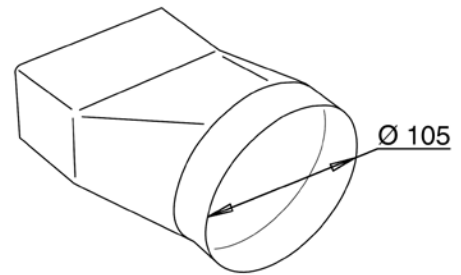

IDENTIFICATION	CODE
FAD	6078005

Air distribution connection

See page 13.

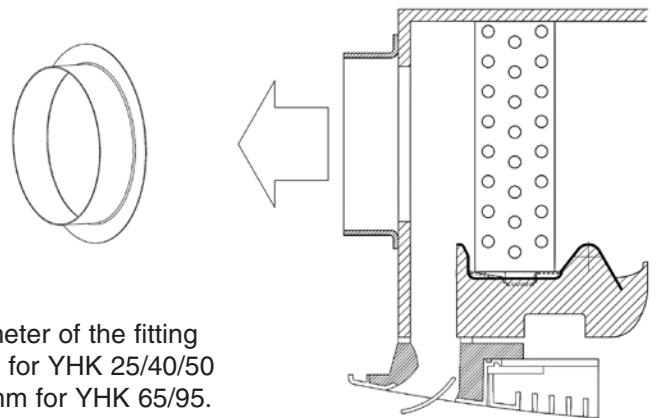

The diameter of the fitting is 150 mm for YHK 25/40/50 and 180 mm for YHK 65/95.

IDENTIFICATION	CODE
CDA 600	9079232
CDA 800	9079233

Fresh air kit

This is used to introduce primary air into the environment directly through the diffuser. The kit includes a flow separator to be fitted inside the cassette, and a circular fitting for connection to the flexible system ducting. The flow of air is sent directly to just one of the outlet louvers, without passing through the coil.

MODEL	YHK 25/40/50	YHK 65/95
IDENTIFICATION	FAK 600	FAK 800
CODE	9079230	9079231

The air flow of fresh air introduced into the environment depend on the inlet static pressure.

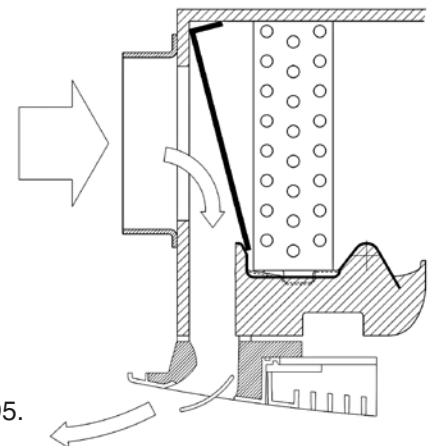

The diameter of the fitting is 150 mm for YHK 25/40/50 and 180 mm for YHK 65/95.

Correlation between flow-rate / static pressure

YHK 25/40/50		YHK 65/95	
m ³ /h	Pa	m ³ /h	Pa
80	3	160	3
120	8	200	8
160	15	300	15
200	25	400	25
240	36	500	36

ON-OFF valves with thermoelectric actuator

VALVE WITH MICROMETRIC LOCKSHIELD VALVE

3 ways



YHK
25-2/25-4
40-2/40-6
50-2/50-6

YHK
65-2/65-4
95-2/95-6

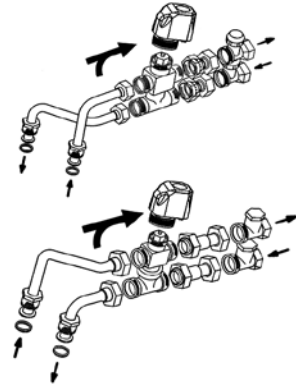

2 ways



YHK
25-2/25-4
40-2/40-6
50-2/50-6

YHK
65-2/65-4
95-2/95-6

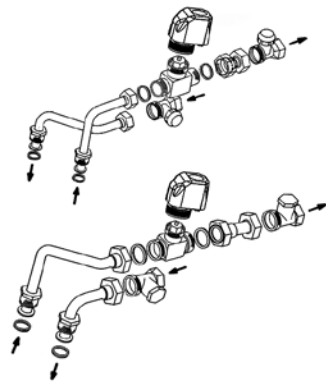

VALVE WITH SIMPLIFIED KIT

3 ways



YHK
25-2/25-4
40-2/40-6
50-2/50-6

YHK
65-2/65-4
95-2/95-6

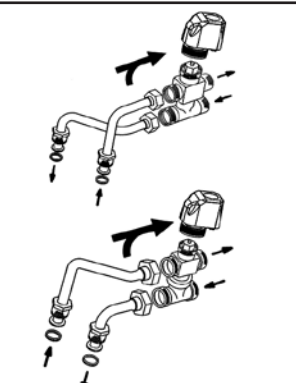

2 ways



YHK
25-2/25-4
40-2/40-6
50-2/50-6

YHK
65-2/65-4
95-2/95-6

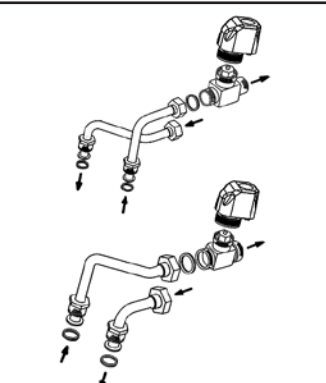

Technical data:

Rated pressure:	16 bar
Max. ambient temperature:	50 °C
Max. water flow temperature:	110 °C
Power:	230 V - 50/60 Hz
Rating:	3 VA
Protection:	IP 43
Travel time:	approx. 3 min.
Max. glycol content of water:	50%

Valves characteristics

Coil type	ECM Model	2 way valves			3 way valves		
		Kvs m ³ /h	Δp _{max} kPa *	Valve ** connection	Kvs m ³ /h	Δp _{max} kPa *	Valve ** connection
Main	25/40/50-2	2,8	50	3/4"	2,5	50	3/4"
	25-4 40/50-6						
	65/95-2	5,2	60	1"	4,5	50	1"
	65-4 / 95-6						
Auxiliary	25-4 40/50-6	2,8	50	3/4"	2,5	50	3/4"
	65-4 / 95-6						

* maximum pressure difference for valve to close ** external thread, flat seal

Valves pressure drop

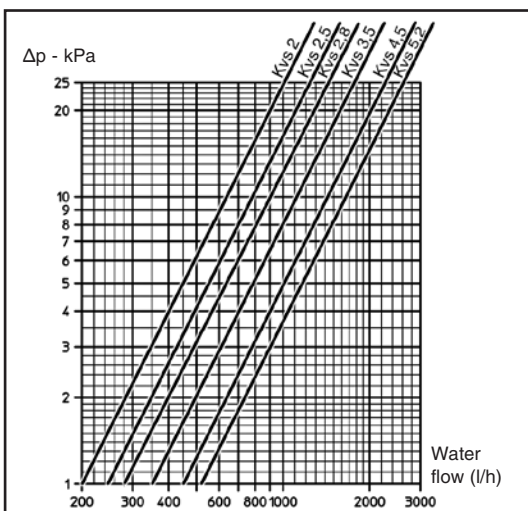

Valve set, 2 or 3 ways, ON-OFF, with thermoelectric actuator. The set includes connection pipes.

Note: The main coil lockshield valve connection is 1/2" female (Kvs 2) for YHK 25/40/50 sizes and 3/4" female (Kvs 3,5) for YHK 65/95 sizes, the auxiliary coil valve connection is 1/2" female (Kvs 2).

Note: The maximum pressure drop across the fully open valve should not exceed 25 kPa for cooling operation and 15 kPa for heating operation.

For 2 way balance valve, refer to page 16.

YHKY-ECM configuration

For this cassette configuration, the 1-10 Vdc signal, which controls the inverter, must be supplied by a controller with the following signal specifications:

Fan Drive Signal

- 0 Vdc = Fan OFF
- >1 Vdc = Fan ON
- 10 Vdc = Maximum speed

ECM BLAC Board

0÷10 Vdc Circuit Input Impedance Value = 68kOhm

YHKY-ECM electric diagram

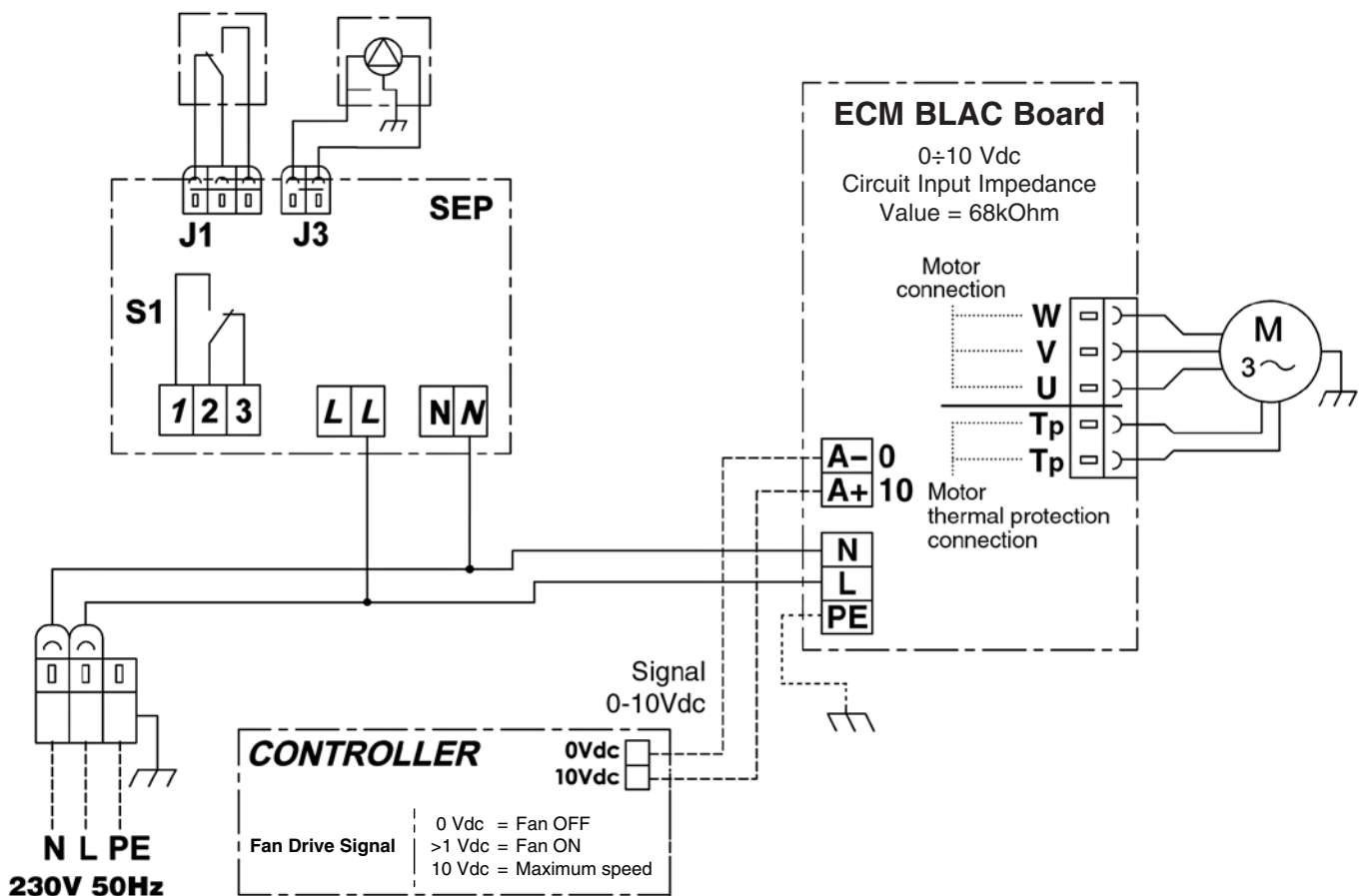

LEGEND

- SEP = Pump control board
- BLAC = Inverter board
- M = Electronic motor
- CONTROLLER = Controller

Wall electronic controls

IDENTIFICATION	CODE
JWC-AU	9066632K



Dimensions: 135x86x24 mm

The control must always be connected with JPF-AU power unit (fitted on the unit) or with JP-AU power unit (not fitted on the unit).

- ON-OFF push button.
- Manual or automatic 3 speed progressive push button.
- Manual, automatic or centralized Summer/Winter switch.
- Summer/Winter/Fan/Auto mode push button.
- Electric heater/IAQ filter activation button.
- Electronic room thermostat for fan control (ON-OFF).
- Electronic room thermostat for valve control (ON-OFF).
- Simultaneous thermostatic control of the valves and fan.
- It allows to control the low temperature cut-out thermostat (NTC).
- It allows to control the chilled water valve (ON-OFF) and the electric heater in the YHK-E version.
- Energy saving push button.
- Presence of a LED signal when the thermostat is on.

N.B.: with 4 pipe installations and continuous chilled and hot water supply, it allows the automatic summer winter change-over in accordance to the room temperature (-1°C = Winter, +1°C = Summer, Neutral Zone 2°C).

Control power absorption: see the JP-AU power unit

IDENTIFICATION	CODE
JTM-B	9066331E



Dimensions: 110x72x25 mm

The control must always be connected with JPF-AU power unit (fitted on the unit) or with JP-AU power unit (not fitted on the unit).

Wall control with display that allows controlling one or more units in Master/Slave mode. The control is equipped with internal sensor to detect the room temperature, which can be defined as a priority compared to the return air sensor on the fan coil.

The JTM-B control features the following functions:

- Switch the unit ON and OFF.
- Temperature set.
- Manual, centralized or automatic Summer/Winter switch.
- Set the fan speed (low, medium, high or autofan).
- Set the operation mode (fan only, cooling, heating; auto for 4 pipe systems with mode selection depending on the air temperature).
- Possibility of use of the low temperature cut-out thermostat NTC mounted on the JP-AU power unit.
- It allows to control the chilled water valve (ON-OFF) and the electric heater in the YHK-E version.
- Time setting.
- Weekly ON/OFF program.

Control power absorption: see the JP-AU power unit

DESCRIPTION	IDENTIFICATION	CODE
Power unit for JWC-AU and JTM-B remote control (fitted on the unit)	JPF-AU	9066641
Power unit for JWC-AU and JTM-B remote control (not fitted on the unit)	JP-AU	9066640

Power unit to be installed on the fan coil (fan coil interface).

- It controls the fan and the valves of the fan coil.
- It is connected to the electric supply.
- It receives the information required from the control.
- Possibility to use the low temperature cut-out thermostat (optional) for the T1 function which allows the return air control.
- Possibility to use the low temperature cut-out thermostat (optional) for the T2 function which controls the summer/winter switch.
- Possibility to use the low temperature cut-out thermostat (optional) for the T3 function as low temperature cut-out thermostat.
- It allows to control up to 10 units (1 master and 9 slaves).
- Max. Network length: 100 meters.
- Max cable length between control and first connected power unit: 20 meters.

Control power absorption: 2,3 VA



Wall electronic controls

IDENTIFICATION	CODE
WM-S-ECM	9066644



Dimensions: 132x87x23,6 mm

0-10V control with display designed to be mounted on the wall or to be installed on a 503 wall box.

- ON-OFF switch.
- Manual 3 speed switch or automatic continuous speed control.
- Manual Summer/Winter switch.
- Summer/Winter/Fan/Auto mode push button.
- Electronic room thermostat for fan control (ON-OFF).
- Electronic room thermostat for valve control (ON-OFF).
- Simultaneous thermostatic control of the valves and fan.
- It allows to control the low temperature cut-out thermostat (NTC).

Control power absorption: 1,2 VA

Wall electronic controls accessories

NTC low temperature cut-out thermostat

To be fitted between the coil fins.

When connecting the control, the NTC probe cable must be separated from the power supply wires.

To be used with WM-S-ECM control and JP-AU power unit.

It stops the fan when the water temperature is lower than 28°C and it starts the fan when is higher than 33°C.

To use as:

- T1 function for the return air control.
- T2 function which controls the summer/winter switch.
- T3 function as low temperature cut-out thermostat.



IDENTIFICATION	CODE
NTC	3021090

T2 sensor

T2 sensor to be placed on the water supply pipe upstream 3 way valves (not to be used with 2 way valve).

The T2 sensor must be used as described below:

- Change-Over for the automatic switch of the operating mode. If water temperature is lower than 20°C, cooling mode is set; on the other hand, if water temperature exceeds 30°C, heating mode is set.

To be used with JP-AU power unit.

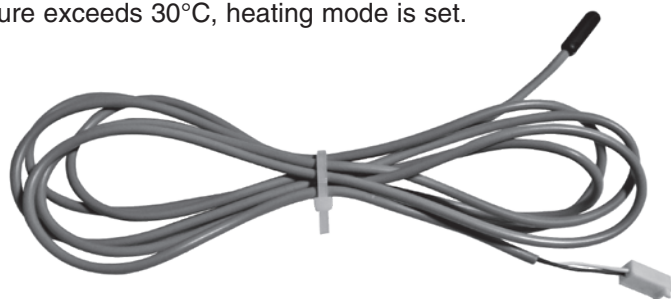

IDENTIFICATION	CODE
T2	9025310

Controls and units for YHKY-ECM-MP versions

All the **YHKY-ECM** units can be supplied in **MP version**. This version includes a wide range of controls, including the **infra-red remote control**, which allows managing one single unit or several units by using the **Modbus RTU - RS 485** communication protocol.

Units can be managed according to the Master/Slave logic (up to 20 units) or by supervisory components.

The system consists in a **MP board** (mounted on models **YHKY-MP** and **YHKY-ECM-MP**) and a series of controls, such as the **JTM-B** wall control, the **RT03** infra-red remote control, the **PSM-DI** multifunction control and the **NET** supervisory program.



JTM-B wall control



PSM-DI multifunction control



RT03 infra-red remote control

PC

NET screenshot



NET software

All the controls and their functions are described in detail from Page 46.

Electric heater YHK-ECM-E

The Cassette 2 pipe models are available with electric resistance that is controlled in place of the heating coil valve. The electric resistance is controlled in place of the hot water valve and not as integration to it. The resistance is hermetically sealed and supplied inside the battery pipes and therefore can be only factory mounted. The electric resistances of the units are for single phase 230V supply. The Cassette includes no. 2 safety thermostats which intervene in case of internal over- heating, opening an auxiliary power relay (included in the shunt box) which stops the power supply to the resistances.

ECM Model	YHK 25-2-E	YHK 40-2-E / 50-2-E	YHK 65-2-E / 95-2-E / 110-2-E
Emission	1500 Watt	2500 Watt	3000 Watt
Supply	230V ~	230V ~	230V ~
Number and Dia. of connecting wires	3 x 1,5 mm ²	3 x 2,5 mm ²	3 x 2,5 mm ²

Note: the cooling emission of the units is 95% of the emission in the tables of page 30.

Electric diagram

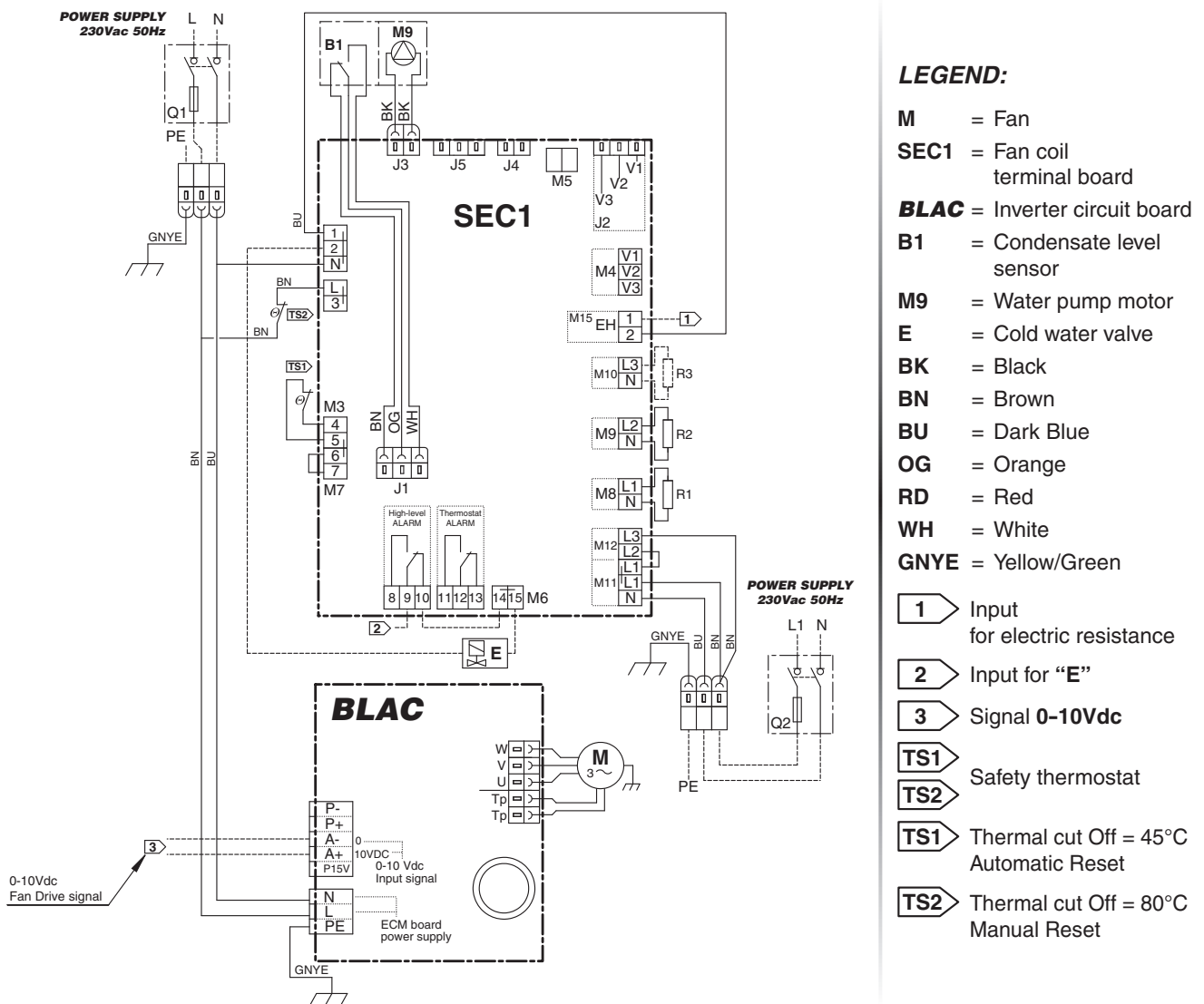

Cassette unit operating limits with electric coil

Max. ambient temperature for Cassette unit with electric coil in heating mode: 25°C

MP controls

MP electronic board

The **MP** electronic board, mounted as per standard on the YHKY-MP and YHKY-ECM-MP versions, is set to carry out different functions and adjustment modes, in order to meet the installation requirements.

These modes are selected by setting the configuration dip switches on the board.

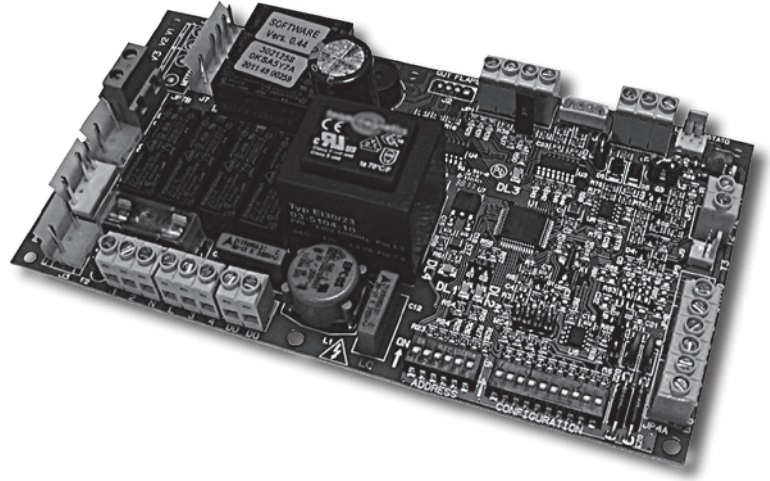

- 2/4 pipe system.
- Fan ON/OFF thermostatic control.
- Valve ON/OFF thermostatic control and continuous ventilation.
- Valve and simultaneous ventilation ON/OFF thermostatic control.
- Fan operation control depending on the coil temperature (cut-out T3 probe fitted), which can be activated only in heating mode or heating and cooling mode.
- Automatic switch of the operating mode by means of T2 water probe (optional) applied on the 2 pipe system.
- Seasonal switch by means of remote contact.
- ON/OFF of the fan coil by means of the remote contact (window or clock contact).
- Electric heater control.

By activating the cut-out T3 probe function, the fan is stopped in winter when the coil temperature is lower than 32°C and started when the temperature reaches 36°C. In summer mode, the fan stops when the temperature inside the coil exceeds 22°C and starts when it drops below 18°C.

The following connections are located on the power board:

- Receiver for infra-red remote control.
- JTM-B wall control.
- RS 485 serial connection to manage several fan coils in Master/Slave configuration or to create a supervisory network.

MP controls

JTM-B wall control

DESCRIPTION	IDENTIFICATION	CODE
Wall control (to be used with YHKY-MP and YHKY-ECM-MP version only)	JTM-B	9066331E

Wall control with display that allows controlling one or more units in Master/Slave mode. The control is equipped with internal sensor to detect the room temperature, which can be defined as a priority compared to the return air sensor on the fan coil.

The **JTM-B** control features the following functions:

- Switch the appliance ON and OFF.
- Temperature set.
- Modify the set point (when used as a +/- 3° variation of the set point configured from NET supervisory program or PSM-DI).
- Set the fan speed (low, medium, high or autofan).
- Set the operation mode (fan only, cooling, heating; auto for 4 pipe systems with mode selection depending on the air temperature).
- Time setting.
- Weekly ON/OFF program.
- Display and change of the fan coil operation parameters.



Dimensions: 110x72x25 mm

MP controls

RT03 infra-red remote control

DESCRIPTION	IDENTIFICATION	CODE
RT03 infra-red remote control with receiver supplied with separate packaging (to be used with YHKY-MP and YHKY-ECM-MP version only)	RCS-RT03	9079117
Receiver for RT03 infra-red remote control supplied with separate packaging (to be used with YHKY-MP and YHKY-ECM-MP version only)	RCS	9079116
Receiver for RT03 infra-red remote control and MD metal diffuser supplied with separate packaging (to be used with YHKY-MP and YHKY-ECM-MP version only)	RS	9066338
RT03 infra-red remote control supplied with separate packaging (to be used with YHKY-MP and YHKY-ECM-MP version only)	RT03	3021203

The infra-red remote control allows setting by a remote position the fan coil operation parameters.

The **RT03** infra-red remote control features the following functions:

- Switch the appliance ON and OFF.
- Temperature set.
- Set the fan speed (low, medium, high or autofan).
- Set the operation mode (fan only, cooling, heating; auto for 4 pipe systems with mode selection depending on the air temperature).
- Time setting.
- 24 hours ON/OFF program.



IDENTIFICATION	CODE
RT03	3021203

**INSTALLATION EXAMPLE
WITH INFRA-RED REMOTE CONTROL**

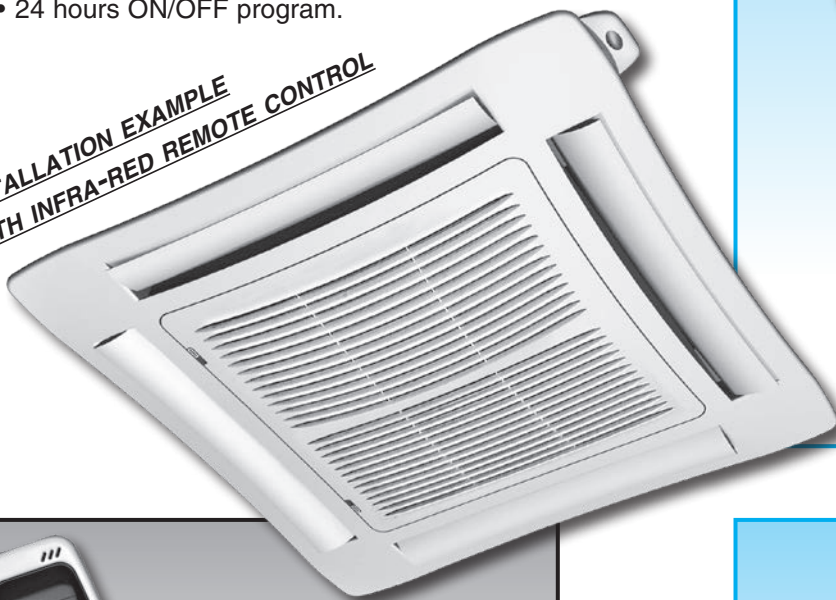

IDENTIFICATION	CODE
RCS-RT03	9079117



IDENTIFICATION	CODE
RCS	9079116

MP controls

A group of **YHKY-MP** can be connected via a serial link and can consequently be managed at the same time by just one **JTM-B** wall control or **RT03** infra-red remote control. Using the special jumper present on the **MP** board, one unit must be configured as the master, and all the others as slaves. It is clear that the remote control must be pointed at the receiver on the master unit. To avoid problems, it is recommended to install and connect the receiver only on the master unit.

With JTM-B wall control

One control for each cassette
(MAXIMUM LENGTH OF THE CONNECTION CABLE = 20 m)



One control for more cassettes (20 units max.)
(MAXIMUM TOTAL LENGTH OF THE CONNECTION CABLE = 800 m)

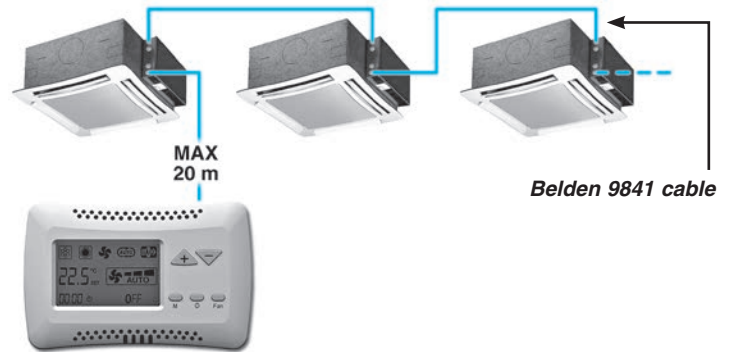

With RT03 infra-red remote control

One control for each cassette



One control for more cassettes (20 units max.)
(MAXIMUM TOTAL LENGTH OF THE CONNECTION CABLE = 800 m)

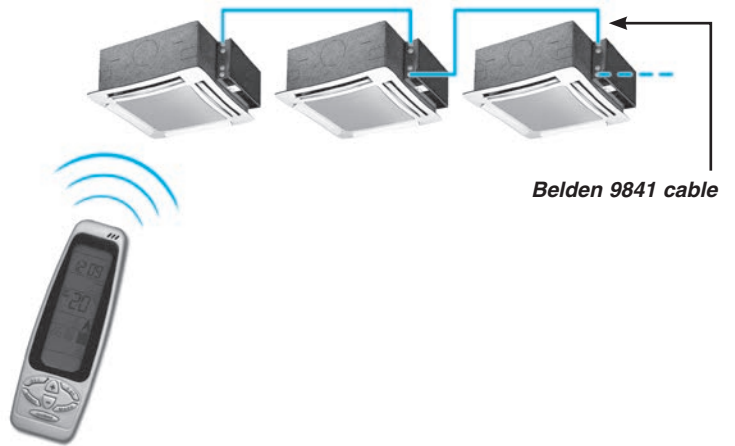

T2 accessory for units with MP electronic board

IDENTIFICATION	CODE
T2	9025310

The T2 sensor can be combined with MP boards to be placed on the water supply pipe upstream 3 way valves (not to be used with 2 way valve).

The T2 sensor must be used as described below:

- Change-Over for 2-pipe system for the automatic switch of the operating mode.
If water temperature is lower than 20°C, cooling mode is set; on the other hand, if water temperature exceeds 30°C, heating mode is set.

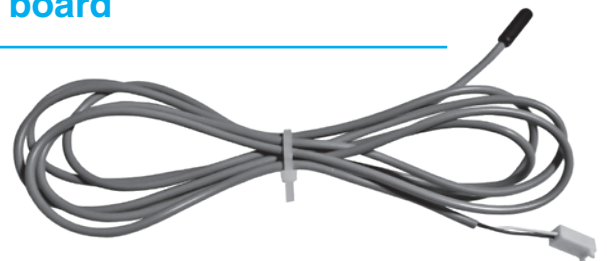

MP controls

PSM-DI multifunction control panel

DESCRIPTION	IDENTIFICATION	CODE
Multifunction control (to be used with YHKY-MP and YHKY-ECM-MP version only)	PSM-DI	3021293

Another option available for the serial communication between the units is the possibility to connect up to 60 **YHK** units in series and manage them with just one wall mounted **PSM-DI** controller. The wall mounted controller can be used to set the operating mode for each individual unit connected, display the operating conditions of each individual unit, and set the ON/OFF time sets for each day of the week (the program can be set for all the units and for a maximum of 10 groups of units).

If more than 60 units need to be connected, two or more multifunction control panels must be used. Each unit must have a MP board.

The **PSM-DI** control is used to manage a series of fan coils, up to a maximum of 60 units (the maximum length of the RS 485 connection cable must not exceed 800 m), from one single control point.

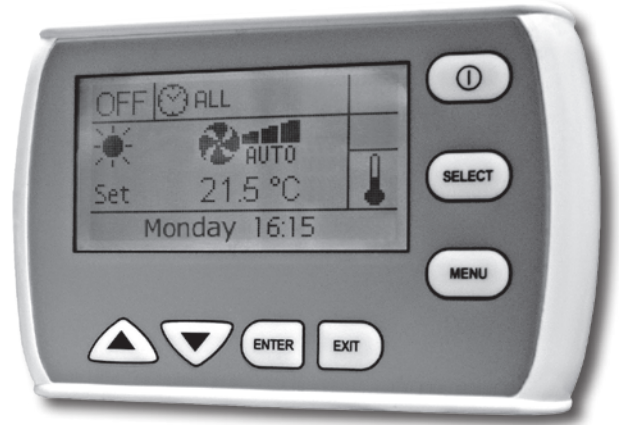

The **PSM-DI** control communicates via a serial line with all the units connected, with the possibility of controlling them all together or individually. In fact, the unique address of each individual fan coil means that all the units can be called at the same time, or the individual unit called, to perform the following functions:

- display the current operating mode, the fan speed, the set point;
- display the room temperature measured on the individual unit;
- turn all the units ON and OFF at the same time or alternatively each unit individually;
- change the operating mode (fan only, heating, cooling, automatic changeover);
- change the set point;
- modify the values and operation parameters of the fan speed.

Each function can then be sent to all the units connected, or alternatively to each individual unit.

Different set points or operating modes can be set for each individual unit.

The **PSM-DI** panel can also be used for the time management of the units over the week. Four ON times and four OFF times can be set on the units for each day of the week. A different Temperature set that will be considered as Operation set for all connected appliances, can be set for each event. If the Temperature set is not entered for the individual event, it must be set during programming for each individual unit or for the entire network.

Units without receiver or with receiver can be connected within the network: the former can receive instructions only from the **PSM-DI** wall mounted panel; while the latter can receive information from both the wall mounted panel (**PSM-DI**) and infra-red remote control. Use the infra-red remote control to force ON mode of the individual unit, if ON/OFF daily time programming has been set. The unit will regain the settings from the **PSM-DI** panel during execution of successive start-up program.

The PSM-DI panel cannot be used together with the NET management program (see next page).

Notes:

- set the configuration Dip Switches of each fan coil as illustrated in the remote control use manual, based on the required solutions.
- only one SIOS board is allowed to be used per each PSM-DI control panel.
- about "Priority pump function": when just one unit calls for, the relay RL1 on the SIOS board is automatically activated to connect a hot water pump.
- the RS 485 network's overall length must not exceed 700/800 metres.

Management system for a network of fan coils

NET program for managing a network of YORK MP fan coils

DESCRIPTION	IDENTIFICATION	CODE
Hardware/software supervisory system (to be used with YHKY-MP and YHKY-ECM-MP version only)	NET	9079118

NET is a centralised control system for networks of YORK MP fan coils, based on software that runs on LINUX™ operating system (the program is provided pre-installed on a PC) and it works in a “stand alone” way, as an ordinary computer, so that it can be connected to a monitor, to a mouse and to a keyboard. By connecting an Ethernet cable is instead possible to work at a distance and visualize the entire program setting-up through whatever browsers. The **NET** software offers a practical and economical solution for managing the units, with the simple click of the mouse.

The main characteristics include:

- simplicity of use;
- an extremely complete and functional weekly program;
- possibility to access the historical operating data for each individual unit connected;
- possibility to save automatically every 6 h the data on SD support and to force the saving with a button;
- possibility of data saving also on other items, as for example USB key;
- visualization of the saved configuration on a new ASUS PC.

The program exploits all the potential of our units with remote controls, representing an addition to the latter.

The **NET** program is a control tool that can be used as a replacement for the remote control, or in parallel, however the settings made using **NET** can have priority over those made using the remote control.

The program can be used to:

- Create uniform groups (groups of units on individual floors, in offices or rooms).
- Save weekly programs configured for different types of operation (summer, winter, mid seasons, closing periods etc.); these can then be recalled and activated with a simple click of the mouse. Weekly on/off cycles can be set for individual units or groups of units.
- Set the operating conditions for each individual unit or groups of units (operating mode, fan speed, temperature setting).
- Set the set point limits for each individual unit or groups of units.
- Switch each individual unit or groups of units ON or OFF.



Management system for a network of fan coils

The main program screen can display and interact with the entire network of units. An individual unit, a group of units or the entire network can be called so as to make modifications to the operating mode and the set point. The user can then check the operating status of each individual unit, read the room temperature, the coil temperature and the operating status of the condensate drain pump or any alarms.

"MONITORING" SCREEN







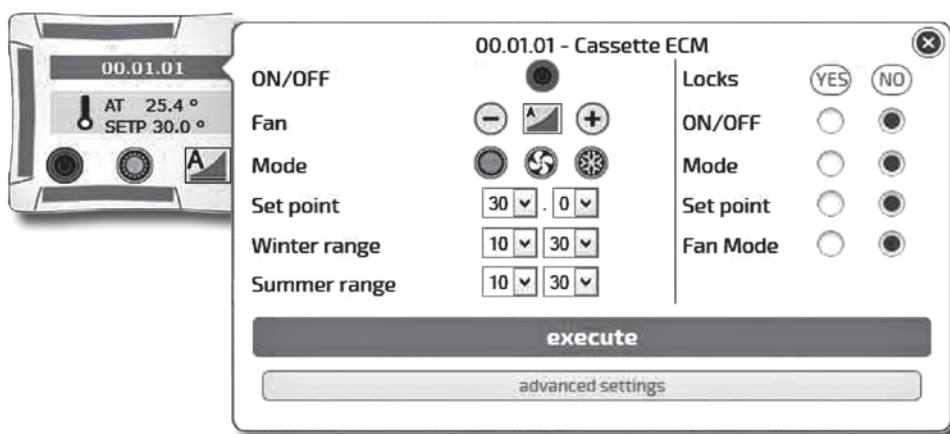





Displaying a unit

The "MONITORING" SCREEN shows the units that are connected to the network and scanned by the program.



The icon of the terminal unit provides the following information:

- Unit name (**00.01.01**)
- Set temperature (SETP)
- Room temperature (AT)
- Unit status: ON (Green)  or OFF (Red) 
- Mode:
 -  Summer
 -  Auto
 -  Winter
 -  Fan only
- Fan speed:
 -  Low
 -  High
 -  Medium
 -  AutoFan

Management system for a network of fan coils

The “Weekly Program” can be used to set the unit operating parameters for each day of the week. Up to 20 different weekly programs can be set.

“EVENT MANAGEMENT” SCREEN

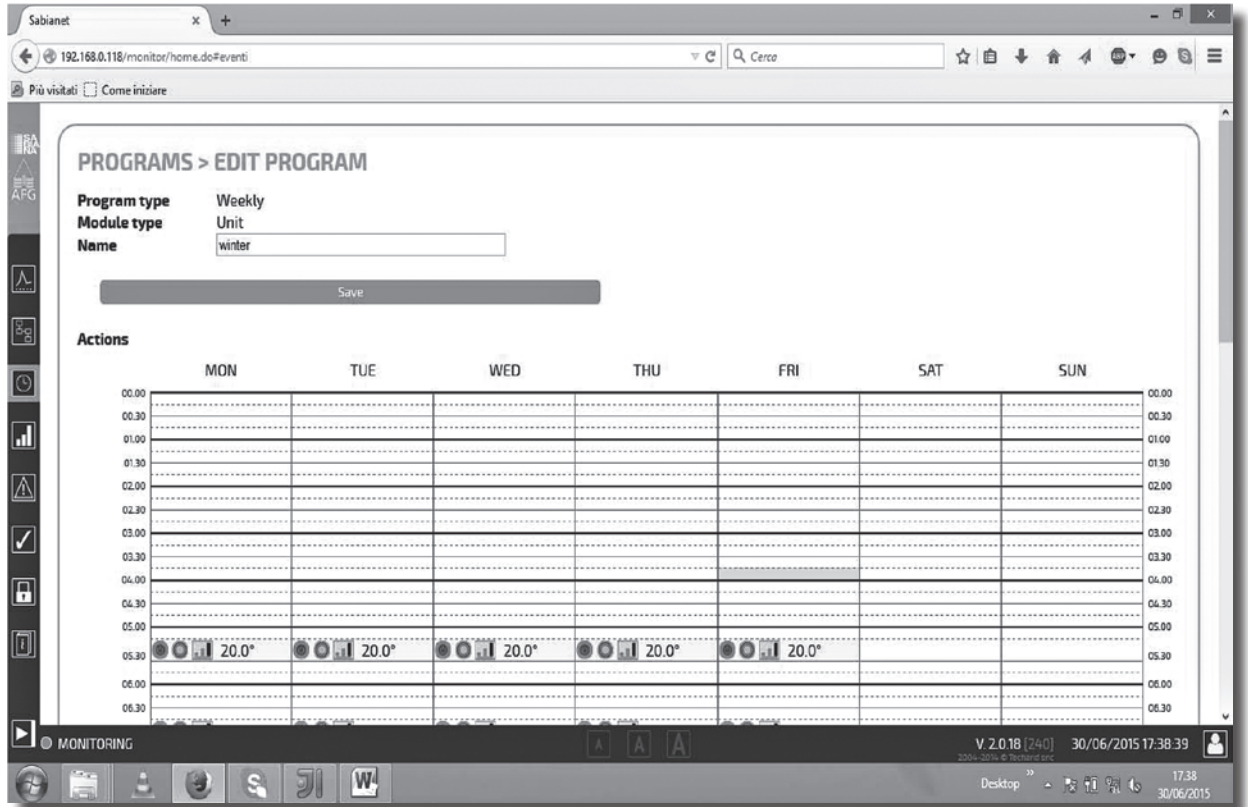

Time bands are available for each day of the week. The time and the type of operation to be performed by the unit can be set for each band. The time and the operating parameters can then be displayed before being sent to the unit and implemented.

Displaying of the parameters and Dip Switches set up

Every time that the reading of the set up Dip Switches results not easy (as for example by the false ceiling installations), it is always possible to display them directly through the NET program.

Group: gruppo 1	FW release: 0.50	Program: gruppo 1 inverno	
Remote control: N.A.	M/S network: N.A.	Unit tree: Level 2 --> Router 1	
Unit status: ON	Mode: WINTER	Fan mode: AUTO	Fan status: OFF
Set Point: 22.0°	Heating status: OFF	Cooling status: [OFF]	Inverter voltage: 0.2
T1: 22.5°	T2: N.A.	T3: 28.5°	
Pump: YES	Remote ON/OFF input: OFF	Window input: OFF	

Unit settings		Alarms
Dip Switch:	OFF ON	
<input type="checkbox"/>	1 2 pipe unit	T1 Fault OFF
<input type="checkbox"/>	2 Thermal station with valves	T2 Fault OFF
<input type="checkbox"/>	3 T3 disabled	T3 Fault OFF
<input type="checkbox"/>	4 T3 only winter when enabled	
<input type="checkbox"/>	5 Simultaneous ventilation of valves	Condensation OFF
<input type="checkbox"/>	6 Unit without electrical heater	
<input type="checkbox"/>	7 T2 as CH Change-over (resistance phase II)	
<input type="checkbox"/>	8 UNIT ALERT	
<input type="checkbox"/>	9 Remote ON/OFF input	
<input type="checkbox"/>	10 MASTER	

Management system for a network of fan coils

Alarm control by E-mail and sms

In addition to the alarm set on the NT display, it is possible to send the ON-OFF alarm notification via E-mail and sms.

ALARMS

Ongoing alarms

At	Address	Unit name	Group	Alarm type
No alarms				

Alarms log

From	To	Address	Unit name	Group	Alarm type
No alarms					

Notification

Event type	eMail						SMS					
	none	instant	after 1 hour	after 3 hours	after 6 hours	at the end	none	instant	after 1 hour	after 3 hours	after 6 hours	at the end
Alarm on unit [any]	<input checked="" type="radio"/>	<input type="radio"/>	<input type="radio"/>	<input type="radio"/>	<input type="radio"/>	<input type="checkbox"/>	<input checked="" type="radio"/>	<input type="radio"/>	<input type="radio"/>	<input type="radio"/>	<input type="radio"/>	<input type="checkbox"/>
Condensate alarm on unit	<input checked="" type="radio"/>	<input type="radio"/>	<input type="radio"/>	<input type="radio"/>	<input type="radio"/>	<input type="checkbox"/>	<input checked="" type="radio"/>	<input type="radio"/>	<input type="radio"/>	<input type="radio"/>	<input type="radio"/>	<input type="checkbox"/>
Probe alarm on unit	<input checked="" type="radio"/>	<input type="radio"/>	<input type="radio"/>	<input type="radio"/>	<input type="radio"/>	<input type="checkbox"/>	<input checked="" type="radio"/>	<input type="radio"/>	<input type="radio"/>	<input type="radio"/>	<input type="radio"/>	<input type="checkbox"/>

Save

RS 485 serial connection cable

Shielded cable to be used:

Belden 9841, RS-485, 1x2x24 AWG SFTP, 120 Ohm

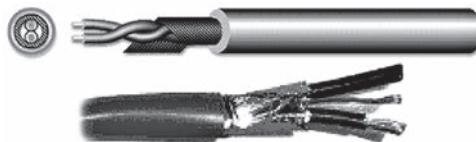

PC NET Software

Connection of a **Cassette YORK YHKY-MP** or **YHKY-ECM-MP** network

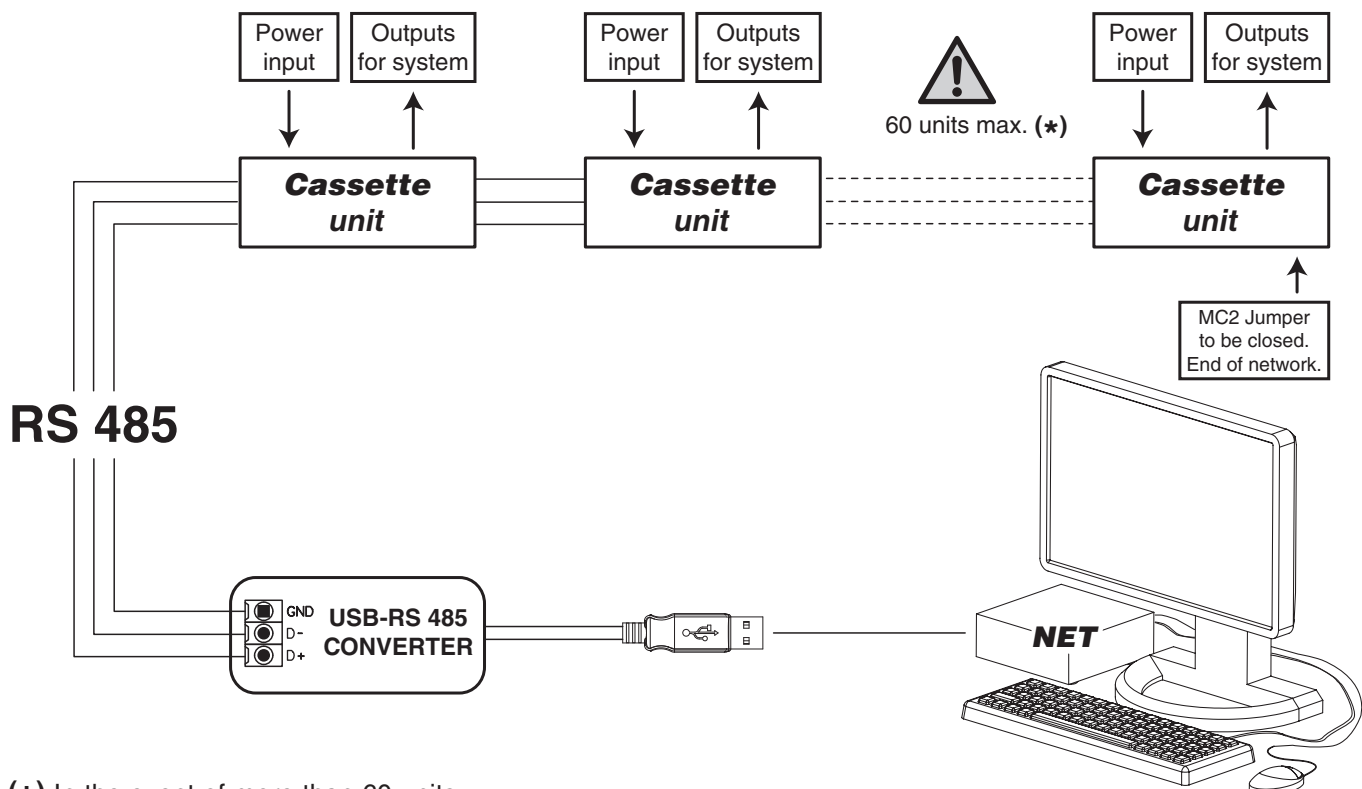

(*) In the event of more than 60 units, add one or more Router-S (see next page).

PSM-DI and NET accessories

IDENTIFICATION	CODE
<i>SIOS</i>	<i>3021292</i>

SIOS is a board equipped with 8 relays with potential free contact to control the activation or deactivation of remote electric utilities. Moreover, the board has 8 digital inlets to display the actuators or external consents, such as motor or other.

The SIOS boards can be connected:

- inside a network managed by NET;
- to a PSM-DI panel (one SIOS for each PSM-DI panel).

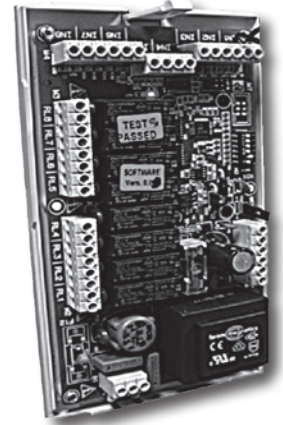

IDENTIFICATION	CODE
<i>Router-S</i>	<i>3021290</i>

The Router-S is an electronic board that:

- allows creating networks with more than 60 units (minimum 2 Router-S are required) or to divide the network (per floor, building, etc.);
- it allows creating a Master/Slave sub-network to be controlled as an independent group.

The Router-S can be used only inside a network managed by NET.

- The number of Router-S to be used is:
- up to 60 units: no Router-S
 - from 61 to 120 units: 2 Router-S
 - every 60 subsequent units: 1 additional Router-S

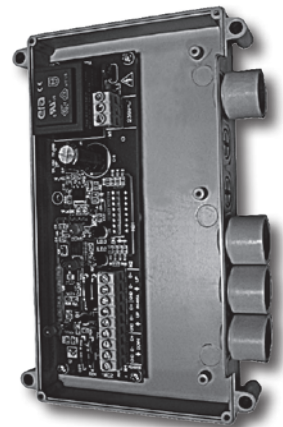

Accessories for BMS Systems which are not provided by YORK

IDENTIFICATION	CODE
<i>Router-BMS</i>	<i>3021340</i>

The Router-BMS (ModBus) is an electronic board to use with BMS systems not supplied by YORK:

- it allows to set-up a Master/Slave sub-network to check as an independent network.

The number of Router-BMS (ModBus) to use is:

- maximum 14 Router-BMS.
- maximum 15 fan coils per Router-BMS.

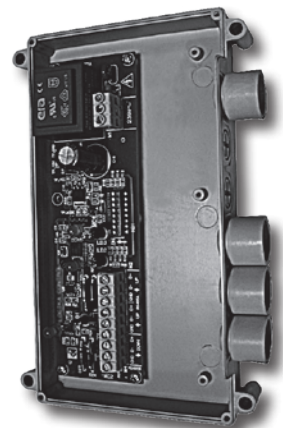

Introduction

The OCA version has been designed for all environments where false ceilings are not featured or cannot be constructed.

The cover cabinet fits perfectly to the air intake and outlet diffuser, maintaining the appealing design that defines the YHK series. The water fittings can be turned to point upwards.

The OCA series includes 7 models, with an installation height of up to 5 m, thanks to the highly flexible adjustment of the air distribution louvers.

All the technical specifications described on the previous pages remain the same, while keeping in mind that:

- the OCA series features one coil only (two pipe systems)
- there is no possibility of fresh air intake
- there is no possibility of additional electric resistance

The OCA version features a special casing in COOL GREY 1C delivered in separate packaging; this must only be fitted after having installed the YHK unit and completed the water and electrical connections.



Dimensions and Weights

YHK 20-2-OCA / YHK 25-2-OCA / YHK 40-2-OCA / YHK 50-2-OCA

Casing code: 9079240

Casing weight: 5 kg (7,5 kg with the packaging)

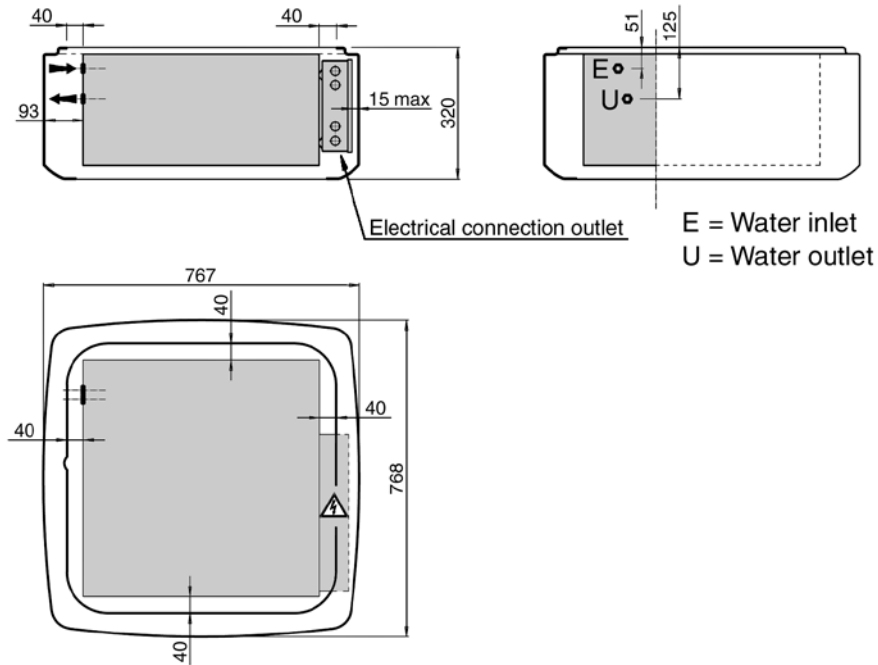

YHK 65-2-OCA / YHK 95-2-OCA / YHK 110-2-OCA

Casing code: 9079250

Casing weight: 10,5 kg (13,5 kg with the packaging)

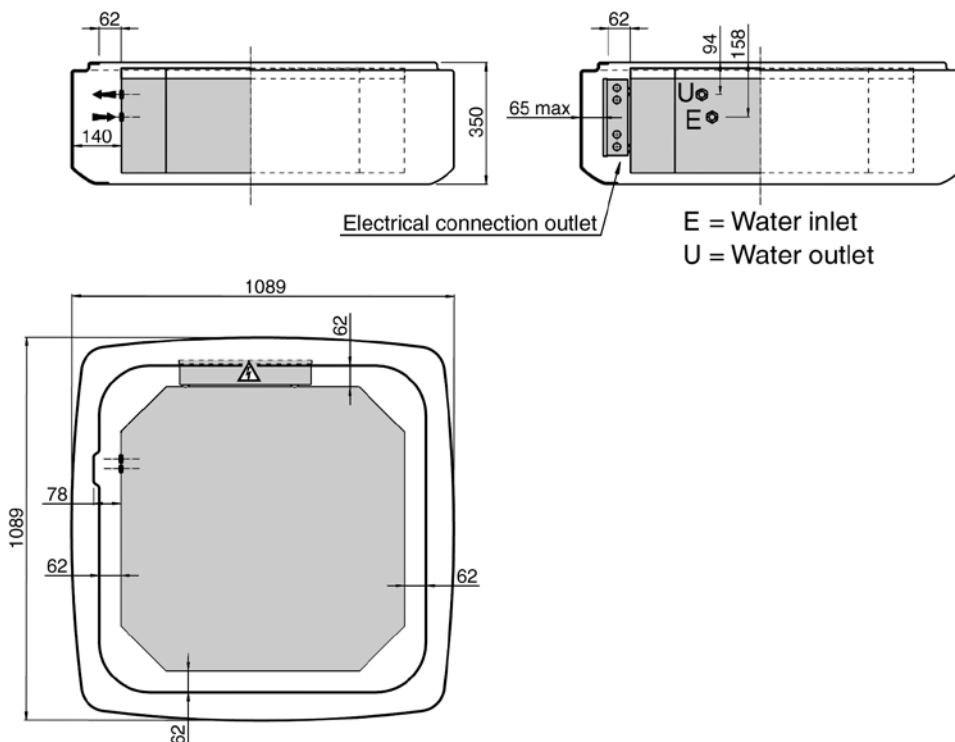

Warning: the electrical and water connections must enter the unit from above and must not interfere with the casing.

Assembly diagram



YHK 20-2-OCA / YHK 25-2-OCA
YHK 40-2-OCA / YHK 50-2-OCA

YHK 65-2-OCA
YHK 95-2-OCA / YHK 110-2-OCA



Components of the casing:

The casing includes:

- A** – 4 corner covers
- B** – 4 bottom brackets
- C** – 4 top brackets
- D** – Condensate collection tray
- E** – Hardware
(45 3.9x9.5mm TCX screws)
- F** – Instruction sheet

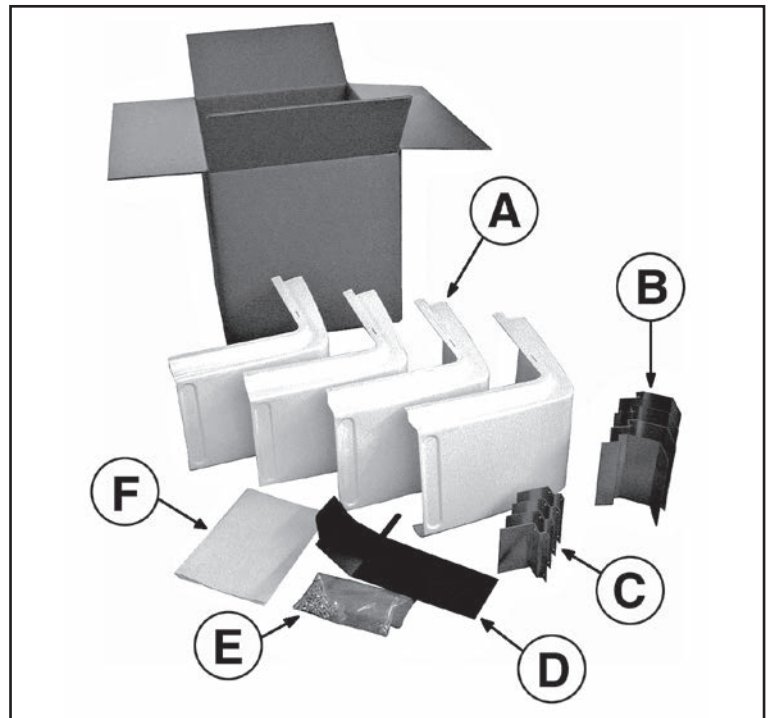

Valve kit

The valve fittings allow the water pipes to be connected from above.

YHK 20-2-OCA / YHK 25-2-OCA
YHK 40-2-OCA / YHK 50-2-OCA

Code 9079155

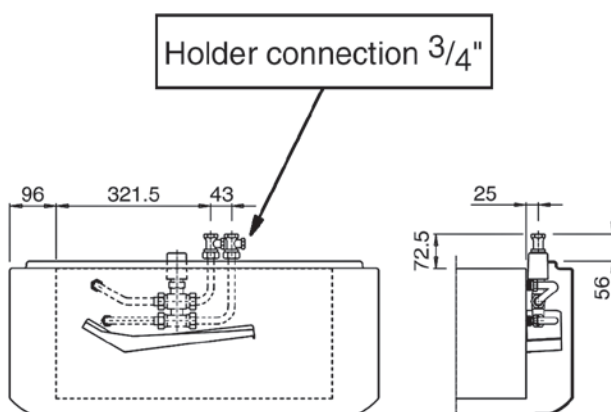

YHK 65-2-OCA
YHK 95-2-OCA / YHK 110-2-OCA

Code 9079156

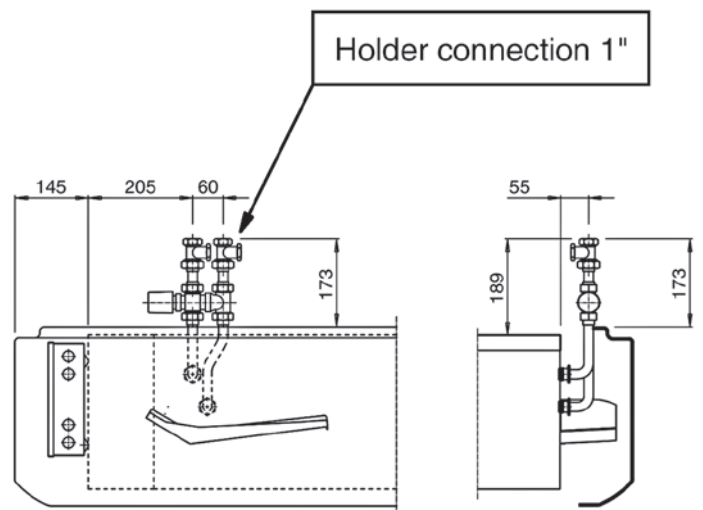

For the specifications of the valves, see page 15.

The descriptions and illustrations provided in this publication are not binding: Johnson Controls reserve the right, whilst maintaining the essential characteristics of the types described and illustrated, to make, at any time, without the requirement to promptly update this piece of literature, any changes that it considers useful for the purpose of improvement or for any other manufacturing or commercial requirements.

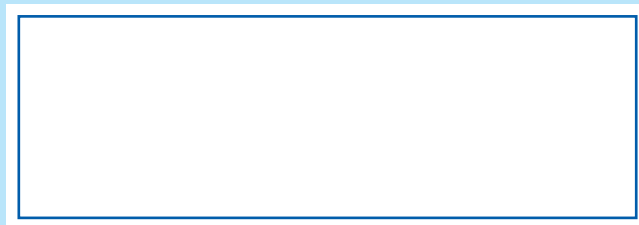

YHK - 06/18

Cod. 99A4790142 I/06/18