

HVAC CONTROL PRODUCTS

The Direct Mount Actuators Accessories Catalogue 2010



DYSTRYBUTOR



www.astra-automatyka.pl
biuro@astra-automatyka.pl
tel. 22 723 92 29



		Non-Spring Return						Spring Return								
		General Purpose			General Purpose			Safety								
		Page	1	2	3		3	7	9	12	14					
		Pieces per pack	M9102 and M9104	M9304	M9108	M9116	M9124	M9132	M9206	M9216	M9208	M9210	M9220	S9208	S9210	S9220
Code Number	Description															
SHAFT COUPLERS / POSITION INDICATORS	ZE-20031	Position indicators for M9108 / M9116 / M9124 / M9132 Series	5													
	M9000-611	Position Indicators, M9210 / M9220 Series	5													
	M9000-Z10DN08	M9304 Adapter kit for 8 mm square shaft	20													
	M9000-Z10DN10	M9304 Adapter kit for 10 mm square shaft	20													
	M9000-Z10DN11	M9304 Adapter kit for 11 mm square shaft	20													
	M9000-Z10DN12	M9304 Adapter kit for 12 mm square shaft	20													
	M9208-601	Standard Coupler Kit, M9208 Series	1													
	M9208-600	Large Coupler Kit, M9208 Series	1													
	M9220-601	Standard Coupler Kit M9210 / M9220 Series	1													
	M9220-600	Jackshaft Coupler Kit, M9210 / M9220 Series	1													
	S9208-608	Square Shaft Adapter 8 mm	5													
	S9208-610	Square Shaft Adapter 10 mm	5													
	M9220-612	Square Shaft Adapter 12 mm, w/Retainer	1													
	M9220-614	Square Shaft Adapter 14 mm, w/Retainer	1													
	M9208-602	Retainer for M9208 Coupler	5													
	M9220-602	Retainer for M9210 / M9220 Coupler	5													
MOUNTING BRACKETS	M9000-152	Reinforcement Plate for Mounting to Thin Sheet Metal	1													
	M9000-158	Tandem Mounting Bracket	1													
	20072S	Antirotation braket M9108 / M9116 / M9124 / M9132	50													
	M9000-604	Standard Mounting Bracket, M(S)9208 and M(S)9210(20) series	1													
DAMPER LINKAGES / ACCESSORIES	M9000-153	Crankarm Kit	1													
	M9208-150	Crankarm Kit	1													
	M9000-150	Damper Mount Linkage Kit	1													
	M9000-ZK	Complete Remote Mounting Kit	1													
	M9000-ZKA	Crankarm Kit	1													
	M9000-ZKH	Crankarm Kit	1													
	M9000-ZKG	Ball Joints	1													
	M9000-151	Remote Mounting Kit, w/Crankarm and Damper Linkage	1													
	M9208-100	Remote Mounting Kit, w/Crankarm	1													
	M9000-170	Remote Mounting Kit (horizontal), w/Crankarm	1													
	M9000-171	Remote Mounting Kit (vertical), w/Crankarm	1													
	M9000-605	Ball Joint for Ø1/4" and Ø5/16" rods, 5/16-24x33/64" thread mount	5													
	M9220-605	Ball Joint for M8x1.25 threaded rod, M8x1.25 x 16.5 mm thread mount	5													

DIRECT MOUNT ACTUATOR ACCESSORIES



		Non-Spring Return						Spring Return								
		General Purpose			General Purpose			Safety								
		Page	1	2	3			3	7	9	12	14				
		Pieces per pack	M9102 and M9104	M9304	M9108	M9116	M9124	M9132	M9206	M9216	M9208	M9210	M9220	S9208	S9210	S9220
Code Number	Description															
VALVE LINKAGES	M9000-155	Manual Handle	1													
	M9000-550	Ball Valve Linkage, DN15 to DN25	1													
	M9000-525-5	Ball Valve Linkage for M9108-xxx-5	1													
	M9000-520-5	Ball Valve Linkage for M9206-xxx-5S	1													
	M9000-510-5	Ball Valve Linkage for M9216 and for M9108-xxx-1N	1													
WEATHERSHIELDS	ZGS.12	IP65 Box for M9100 series	1													
	ZGS.16	IP65 Box for M9100 series	1													
	ZGS.18	IP65 Box for M9100 series	1													
	ZGS.20	IP65 Box for M9100 series	1													
	ZGS.12V	IP65 Box for M9100 series	1													
	ZGF.12	IP65 Box for M9216 series	1													
	ZGF.16	IP65 Box for M9216 series	1													
	ZGF.18	IP65 Box for M9216 series	1													
	ZGF.20	IP65 Box for M9216 series	1													
	ZGF.12V	IP65 Box for M9216 series	1													
ADJ. STOP	M9208-603	Adjustable Stop Kit	1													
	M9220-603	Adjustable Stop Kit	1													
TOOLS	M9208-605	Manual Crank, Short, crank radius 1-13/16" (46.5 mm)	5													
	M9220-604	Manual Crank	5													
MISCELLANEOUS	M9000-PA	Position transmitter	1													
	M9000-PF	Position transmitter	1													
	ST1.72E	Duct Thermal Fuse, max. 72 °C	1													
	ST1.90E	Duct Thermal Fuse, max. 90 °C	1													
	ST1.72W	Duct Thermal Fuse, elbow connection, max. 72 °C	1													
	ST1.90W	Duct Thermal Fuse, elbow connection, max. 90 °C	1													

DIRECT MOUNT ACTUATOR ACCESSORIES



M9102 and M9104 Series Accessories



Code Number	Description
M9000-550	Linkage Kit for DN15, DN20 and DN25 size VG1000 Series Ball Valves for max. fluid temperature 100 °C. Includes adapter bracket, drive shaft, handle, M4 x 60 machine screw, two No. 10-24 thread forming screws, installation instructions for M9104 series only.

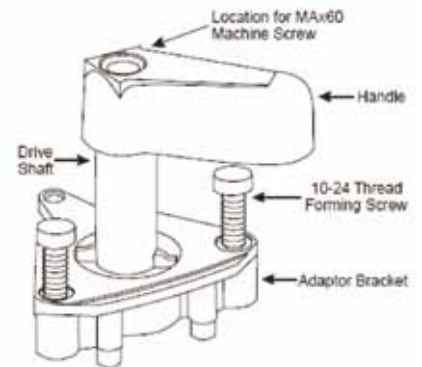

DIRECT MOUNT ACTUATOR ACCESSORIES



M9304 Series Accessories



Code Number	Description
M9000-Z10DN8	Adapter kit for 8 mm square shaft.



M9000-Z10DN10	Adapter kit for 10 mm square shaft.
---------------	-------------------------------------



M9000-Z10DN11	Adapter kit for 11 mm square shaft.
---------------	-------------------------------------



M9000-Z10DN12	Adapter kit for 12 mm square shaft.
---------------	-------------------------------------

M9108 / M9116 / M9124 / M9132 and M9206 / M9216 Series Accessories



Code Number **Description**

ZE-20031 Pointer.



M9000-150 Damper mounting kit for remote inside-duct mounting an M9108, M9116 or M9124 Series actuator to a three-blade or larger damper. Includes universal mounting bracket.

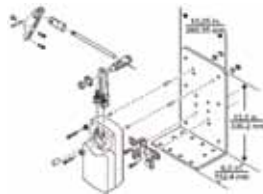

M9000-151 Base mount linkage provides duct mounting for M9108, M9116 and M9124 Series actuators. (Not for use with M9132 Series actuators or tandem applications.). Use the M9000-151 linkage only on a three-blade or larger damper.



M9000-152 Reinforcing plate for mounting applications on thin sheet metal.



M9000-155 Manual handle for positioning a damper or valve when the power is removed from the actuator.



M9000-158 Mounting kit to tandem-mount two M9116-GGx / M9124-AGx / M9124-GGx / M9132-AGx / M9132-GGx. Use two actuators from the same torque and model group. Do not mix actuator models or torque rating. Mount the M9000-158 kit on the inside or outside of a duct, damper frame or air handling unit. When mounted with the M9000-158 kit, the actuators are directly coupled to a damper blade pin extension or a jackshaft.

DIRECT MOUNT ACTUATOR ACCESSORIES



M9108 / M9116 / M9124 / M9132 and M9206 / M9216 Series Accessories



Code Number	Description
M9000-ZK	Complete Remote mounting kit, include universal crank arm, adapter and two ball joints.



M9000-ZKA	Universal crank arm and adapter to be fixed to the damper shaft.
-----------	--



M9000-ZKH	Crank arm to be fixed to the actuator, including a center bolt.
-----------	---



M9000-ZKG	Two ball joints to be fixed to ZKA and ZKH and to be linked by a rod with an 8 mm thread. Two M8 nuts to secure the rod.
-----------	---

DIRECT MOUNT ACTUATOR ACCESSORIES



M9108 / M9116 / M9124 / M9132 and M9206 / M9216 Series Accessories



M9000-525-5 Linkage kit for VG1000 ball valves and M9108-xxx-5 series actuators.



M9000-520-5 Linkage kit for VG1000 ball valves and M9206 series actuators.



M9000-510-5 Linkage kit for VG1000 ball valves, M9216 and M9108-xxx-1N series actuators.



Code Number	Description
20072S	Replacement anti-rotation bracket.

DIRECT MOUNT ACTUATOR ACCESSORIES



M9108 / M9116 / M9124 / M9132 and M9206 / M9216 Series Accessories



M9000-PA
M9000-PF

Position transmitter for modulating actuators
M9000-PA in surface mounting box, M9000-PF for panel front mounting.

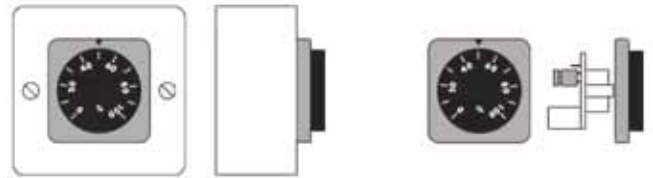

IP65 protective box.
ZGS.x for M9100 non spring return series
ZGF.x for M9216 spring return series

ZGS.12	For 12 mm round shaft.
ZGS.16	For 16 mm round shaft.
ZGS.18	For 18 mm round shaft.
ZGS.20	For 20 mm round shaft.
ZGS.12V	For 12 mm square shaft.
ZGF.12	For 12 mm round shaft.
ZGF.16	For 16 mm round shaft.
ZGF.18	For 18 mm round shaft.
ZGF.20	For 20 mm round shaft.
ZGF.12V	For 12 mm square shaft.



M9208 Series Accessories



Code Number	Description
M9000-604	Replacement anti-rotation bracket kit (with screws).



M9000-605	Ball joint for 1/4 in. and 5/16 in. diameter rods, 5/16-24 x 33/64 thread mount.
-----------	--



M9208-100	Remote mounting kit, includes mounting bracket, M9208-150 crank arm, ball joint, and mounting fasteners.
-----------	--



M9208-150	Crank arm.
-----------	------------

DIRECT MOUNT ACTUATOR ACCESSORIES



M9208 Series Accessories



Code Number	Description
M9208-600	Kit, gripper for 19 mm (3/4 in.) round shafts with retention clip.



M9208-601	Kit, gripper for 8 to 16 mm (5/16 to 5/8 in.) round shafts with retention clip.
-----------	---



M9208-602	Kit, replacement retention clips.
-----------	-----------------------------------



M9208-603	Kit, adjustable stop for M9208 Series actuators.
-----------	--



M9208-604	Kit, replacement cranks, long 75 mm. crank radius.
-----------	--



M9808-605	Kit, Replacement cranks, short 46.5 mm. crank radius.
-----------	---

M9210 and M9220 Series Accessories

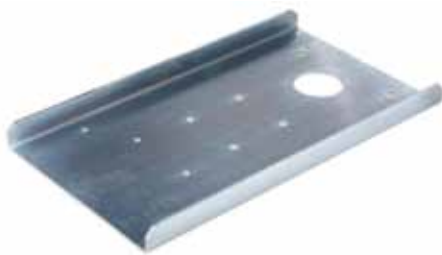

Code Number

Description

M9000-152

Reinforcing plate for mounting applications on thin sheet metal.



M9000-153

Crank arm kit for remote mounting.



M9000-158

Tandem mounting kit, used to mount two M9220 Series actuators. Kit includes top bracket, bottom bracket and six self-tapping screws.



M9000-170

Remote mounting kit (horizontal). Kit includes mounting bracket, M9000-153 crank arm, ball joint, and mounting bolts.

DIRECT MOUNT ACTUATOR ACCESSORIES



M9210 and M9220 Series Accessories



Code Number	Description
M9000-171	Remote mounting kit (vertical). Kit includes mounting bracket, M9000-153 crank arm, ball joint, and mounting bolts.
M9000-604	Replacement anti-rotation bracket kit (with screws).
M9000-605	Ball joint for 1/4 in. and 5/16 in. diameter rods, 5/16-24 x 33/64 thread mount.
M9000-611	Pointer.
M9220-600	25 mm (1 in.) jackshaft coupler kit (with locking clip) for mounting on dampers with 19 to 27 mm (3/4 to 1-1/16 in.) round shafts; or 16, 18 and 19 mm (5/8 and 3/4 in.) square shafts.
M9220-601	Replacement coupler (with locking clip) for mounting on dampers with 12 to 19 mm (1/2 to 3/4 in.) round shafts; or 10, 12 and 14 mm (3/8 and 1/2 in.) square shafts.



M9210 and M9220 Series Accessories



Code Number	Description
M9220-602	Replacement locking clips.



M9220-603	Adjustable stop kit.
-----------	----------------------



M9220-604	Replacement manual override cranks.
-----------	-------------------------------------



M9220-605	Replacement ball joint.
-----------	-------------------------



M9220-610	Replacement shaft gripper, 10 mm square shaft with locking clip.
-----------	--

M9220-612	Replacement shaft gripper, 12 mm square shaft with locking clip.
-----------	--

M9220-614	Replacement shaft gripper, 14 mm square shaft with locking clip.
-----------	--

DIRECT MOUNT ACTUATOR ACCESSORIES

S9208 / S9210 and S9220 Series Accessories



Code Number	Description
M9000-604	Replacement anti-rotation bracket kit (with screws).



M9208-604	Kit, replacement cranks, long 75 mm. crank radius, only for S9208.
-----------	--



M9808-605	Kit, Replacement cranks, short 46.5 mm. crank radius, only for S9208.
-----------	---

S9208 / S9210 and S9220 Series Accessories



Code Number

Description

S9208-608

Kit, replacement adapter for 8 mm square shafts, only for S9208.



S9208-610

Kit, replacement adapter for 10 mm square shafts, only for S9208.



ST1.72E

Duct Thermal fuse, 72 °C.

ST1.90E

Duct Thermal fuse, 90 °C.

ST1.72W

Duct Thermal fuse, elbow connection, 72 °C.

ST1.90W

Duct Thermal fuse, elbow connection, 90 °C.

DIRECT MOUNT ACTUATOR ACCESSORIES

S9208 / S9210 and S9220 Series Accessories



M9220-604 Replacement manual override cranks, only for S9210 and S9220.

M9220-610 Replacement shaft gripper, 10 mm square shaft with locking clip, only for S9210 and S9220.

M9220-612 Replacement shaft gripper, 12 mm square shaft with locking clip, only for S9210 and S9220.

M9220-614 Replacement shaft gripper, 14 mm square shaft with locking clip, only for S9210 and S9220.

