

ADS10-24,-230 ADS20-24, -230

SPRING RETURN DIRECT-COUPLED DAMPER ACTUATORS 10/20 Nm (88/177 lb-in) FOR 2-POSITION CONTROL

PRODUCT DATA



GENERAL

These direct-coupled damper actuators provide two-position control for:

- air dampers,
- VAV units,
- air handlers,
- ventilation flaps,
- louvers, and
- reliable control for air damper applications with up to 1.5 m² / 16 sq.ft (10 Nm / 88 lb-in) or 4.6 m² / 50 sq.ft. (20 Nm / 177 lb-in) (seal-less dampers; air friction-dependent).

FEATURES

- Self-centering shaft adapter
- Removable access cover
- Mechanical end limits (non-adjustable)
- Rotation direction selectable by choice of mounting orientation
- Mountable in any orientation (IP54 only when mounted on a horizontal shaft with access cover below the shaft)
- Mechanical position indicator

SPECIFICATIONS

Supply voltage

ADSxx-24	24 Vac ±20% / 24 Vdc 50/60 Hz
ADSxx-230	230 Vac ±20%, 50/60 Hz

Nominal voltage

ADSxx-24	24 Vac / 24 Vdc, 50/60 Hz
ADSxx-230	230 Vac, 50/60 Hz

All values stated hereinafter apply to operation under nominal voltage conditions.

Power consumption

	Holding	Driving
ADS10-24	8 VA	30 VA
ADS20-24	8 VA	40 VA
ADS10-230	13 VA	45 VA
ADS20-230	13 VA	60 VA

Ambient limits

Ambient operating limits	-40...+60 °C
Ambient storage limits	-40...+70 °C
Relative humidity	5...95%, non-condensing

Safety

Protection standard	IP54
Protection class	II as per EN 60730-1
Overvoltage category	III

Lifetime

Full strokes	50000
Repositions	1.5 million
Full stroke spring return	50000

Mounting

Round damper shaft	10...27 mm
Square damper shaft	13...19 mm
Shaft length	25 mm

Auxiliary switches

Optional accessory ACCA-AD2034-SW2

Torque rating

ADS10-xx	10 Nm (88 lb-in)
ADS20-xx	20 Nm (177 lb-in)

Runtime

45 ± 5 sec (50 Hz)

Spring return timing

20 sec (50 Hz)

Rotation stroke

95° ± 3°

Dimensions

see Fig. 7 on page 6

Weight

3.2 kg

Noise rating

Driving	50 dB(A)
Holding	20 dB(A) (no audible noise)
Spring return	65 dB(A)

MODELS

order number	supply voltage	end switches	power consumption	torque
ADS10-24	24 Vac	--	30 VA (driving) / 8 VA (holding)	10 Nm (88 lb-in)
ADS10-230	230 Vac	--	45 VA (driving) / 13 VA (holding)	
ADS20-24	24 Vac	--	40 VA (driving) / 8 VA (holding)	20 Nm (177 lb-in)
ADS20-230	230 Vac	--	60 VA (driving) / 13 VA (holding)	

Product Identification System

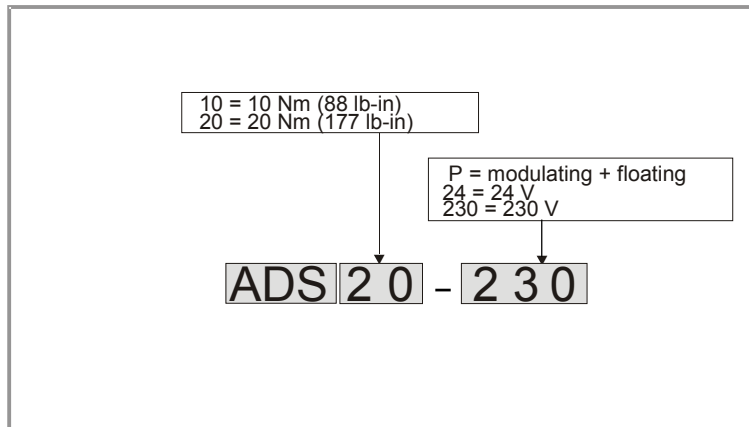

Fig. 1. Product Identification System

OPERATION / FUNCTIONS

Contents of Package

- 1 Self-centering shaft adapter
- 2 Retainer clip
- 3 Rotational angle scales (0...90° / 90...0°)
- 4 Mechanical end limits (non-adjustable)
- 5 Hex wrench for manual adjustment
- 6 Rotation direction switch
- 7 Access cover

Rotary Movement

The actuators are designed to open a damper by driving the damper shaft in either a clockwise or counterclockwise direction.

NOTE: Actuators are shipped in the fully-closed (spring return) position.

Two-Position Control

The two-position actuators are capable of being operated by a two-position (open/close) controller. Refer to wiring diagrams for correct connection.

Position Indication

An arrow molded into the hub points to tick marks on the label to indicate the hub rotary position.

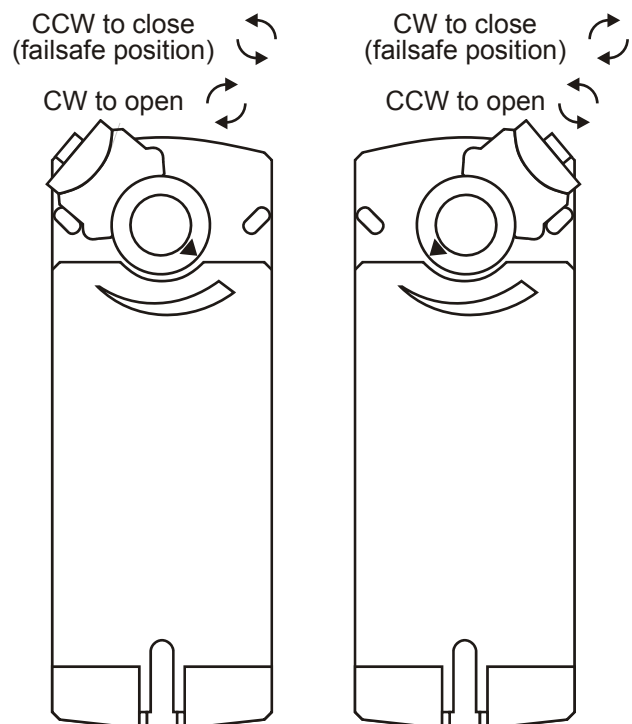

Fig. 2. Mounting orientation

Manual Adjustment

IMPORTANT

To prevent equipment damage, before manual adjustment, you must remove power.

The actuator can be **operated** with no power present. Use this feature during installation or to move and lock the damper or valve shaft position when there is no power.

Operating the Manual Positioning

To operate the manual positioning with no power, proceed as follows:

1. If the power is ON, turn it OFF.
2. Insert the supplied hex wrench (key) as shown in Fig. 3.
3. Rotate the key in the direction indicated on the cover.
4. Once the desired position has been reached, hold the key to prevent the spring return from moving the actuator.
5. With the key held in place, use a screwdriver to turn the gear train lock pin in the indicated direction until the detent is reached.

NOTE: At the detent, the pin resists further rotation.

6. Remove the key without rotating it further.

Releasing the Manual Positioning

To release the manual positioning with no power present, proceed as follows:

1. Insert the supplied key.
2. Turn the key $\frac{1}{4}$ of a turn in the direction indicated on the cover.
3. Remove the key without engaging the gear train lock pin.
4. The spring will return the actuator to the failsafe position.

NOTE: Once power is restored, the actuator will return to normal automated control.

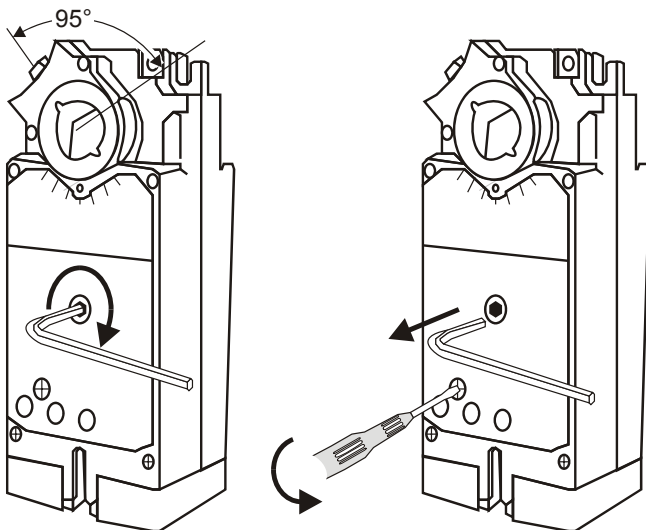

Fig. 3. Manual positioning

End Switches

NOTE: End switch functionality is provided by optional accessory ACCA-AD2034-SW2.

ACCA-AD2034-SW2 provides auxiliary switches which are freely adjustable between 0 and 90°.

Mechanical Stroke Limit Reduction

For applications requiring a span of less than 95°, a simple adjustment can be made. When the rotational mounting of the shaft coupling is changed, the actuator drives less than the full 95° stroke.

The stroke is adjustable in 5° increments. Once adjusted, the actuator drives until the shaft coupling reaches the mechanical stop (part of the housing). The stop causes the motor to discontinue driving, and the shaft coupling drives no farther. When the actuator returns, it stops at the fail-safe position.

To set the fail-safe position, proceed as follows:

1. Remove the retainer clip from the shaft coupling and set it aside for later use.
2. Remove the shaft coupling from the actuator.
3. Rotate the coupling to the desired fail-safe position, aligning it based on the stroke labeling. See Fig. 4.

EXAMPLE: Setting the shaft coupling to an approx. fail-safe position of 35° (as indicated on the housing) limits the stroke to 60° (see Fig. 4).

4. Install the shaft coupling at this position.
5. Replace the retainer clip on the shaft coupling using the groove of the coupling.
6. If necessary, replace the holder and position indicator on the shaft coupling.

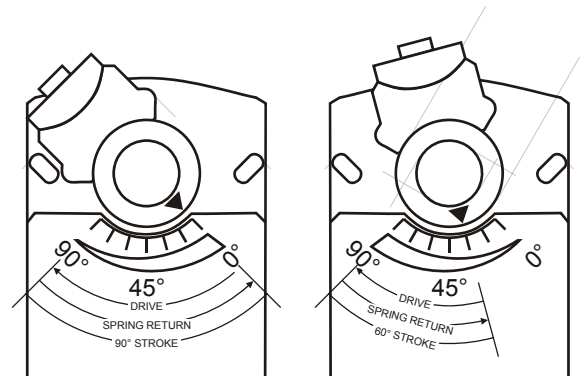

Fig. 4. Stroke reduction

INSTALLATION

These actuators are designed for single-point mounting.

IMPORTANT

To prevent equipment damage, before manual operation, you must remove power.

Mounting Instructions

All information and steps are included in the Installation Instructions supplied with the actuator.

Mounting Position

The actuators can be mounted in any position (IP54 only when mounted on a horizontal shaft with access cover below the shaft). Choose a mounting position permitting easy access to the actuator's cables and controls. When stationing outdoors, equip with suitable cover to protect against UV and rain.

Mounting Bracket and Screws

If the actuator is to be mounted directly on a damper shaft, use the mounting bracket included in the delivery package.

Self-Centering Shaft Adapter

The self-centering shaft adapter can be used for shafts having various diameters and shapes (round: 10...27 mm; square: 13...19 mm).

In the case of short shafts, the shaft adapter may be reversed and mounted on the duct side.

Stroke

The stroke amounts to 95° ($\pm 3^\circ$) and is mechanically limited by end limits (non-adjustable).

Wiring

Connecting to the Power Supply

In order to comply with protection class II, the power source of 24 V actuators must be reliably separated from the network power supply circuits as per DIN VDE 0106, part 101.

Access Cover

To facilitate wiring the actuator to the controller, the access cover can be detached from the actuator.

IMPORTANT

Remove power before detaching the access cover. Once the access cover has been removed, please take care to avoid damaging any of the parts now accessible.

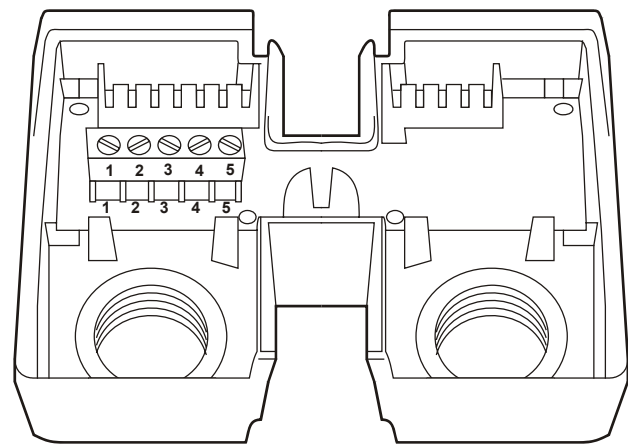

Fig. 5. Access cover (ADS10-24)

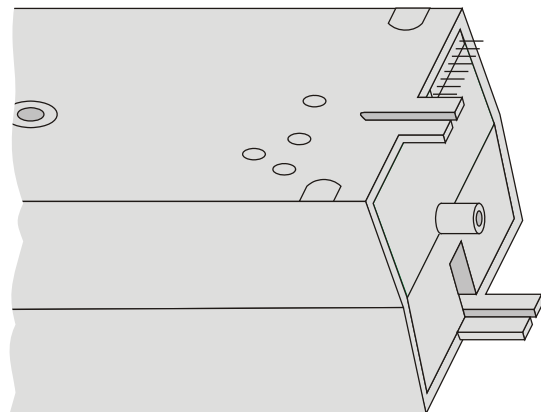
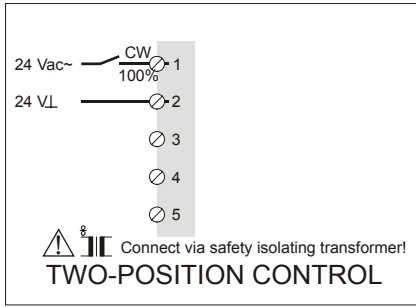
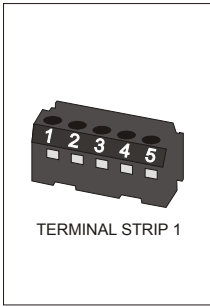

Fig. 6. ADS20-24 with access cover removed

Wiring Diagrams

ADS10-24 / ADS20-24



ADS10-230 / ADS20-230

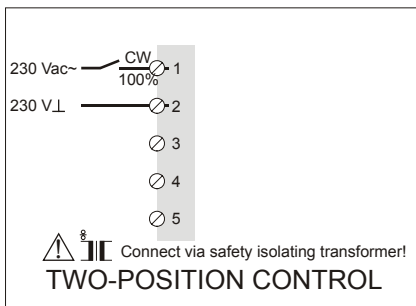
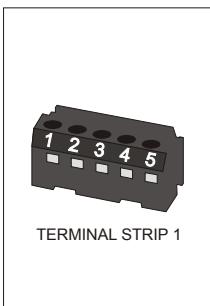

ACCA-AD2034-SW2

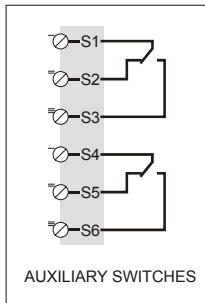
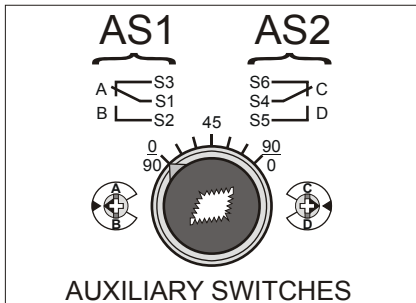
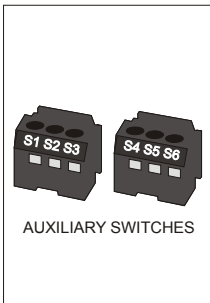

DIMENSIONS

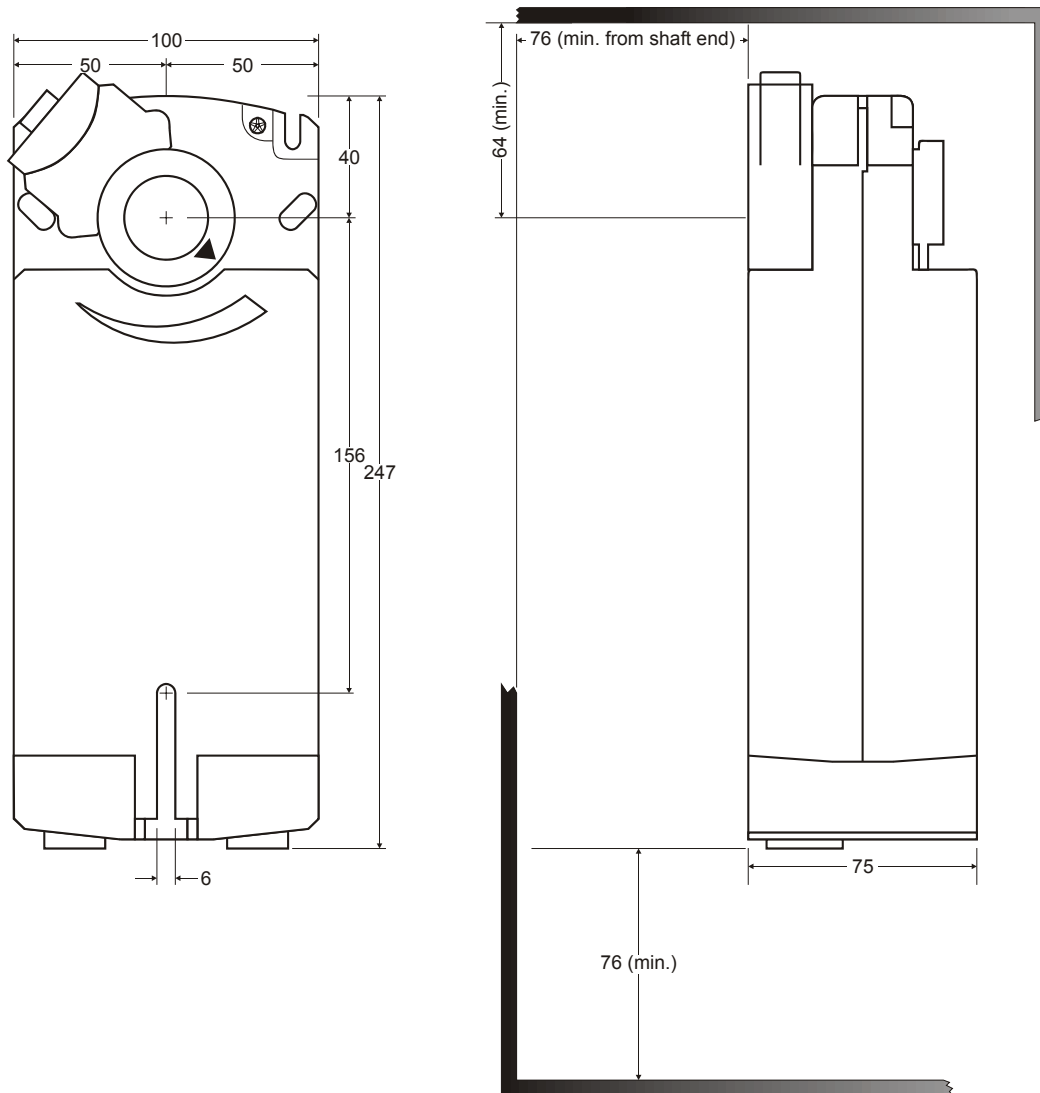



Fig. 7. Dimensions (in mm)

DISPOSAL



WEEE Directive:

At the end of their useful life the packaging and product should be disposed of via a suitable recycling centre.

Do not dispose of with normal household waste.

Do not burn.

Manufactured for and on behalf of the Environmental and Combustion Controls Division of Honeywell Technologies Sàrl, Ecublens, Route du Bois 37, Switzerland by its Authorized Representative.

Trend Control Systems Ltd reserves the right to revise this publication from time to time and make changes to the content hereof without obligation to notify any person of such revisions or changes.

Trend Control Systems Limited

P.O. Box 34 Horsham, West Sussex, RH12 2YF, UK. Tel: +44 (0)1403 211888, Fax: +44 (0)1403 241608, www.trend-controls.com