

SWL

Air flow monitoring

The SLF15 sensor can be used in combination with an ASL... evaluation device to monitor the flow in the air (e.g. in air-conditioning systems).

The switching point is adjustable. While the fan starts up the switch-on bypass is active. The bypass duration (2 – 60 s) is adjustable.

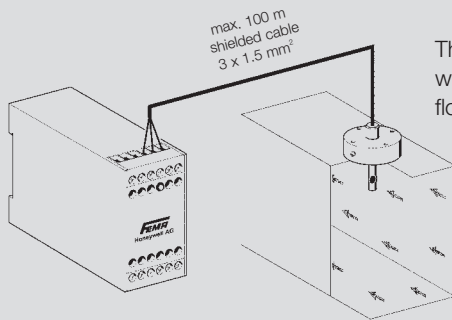

Technical data of sensor

General

Fast-reacting air flow sensor with movable flange for installation in air ducts. With temperature compensation, suitable for media with rapid temperature changes.

Medium temperature -20...+100°C

Compensation behavior

(Reaction speed on change in medium temperature) fast, approx. 0.3 s

Installation depth 150 mm

Sensor tube diameter 10 mm

Sensor tube material nickel-plated brass

Measuring element

Insensitive to moisture (can be cleaned in water). Sensitive to mechanical deformation (care must be taken when cleaning with hard objects).

Protection class IP 32

Electrical connection

Terminal strip accessible after removal of cover. 3-wire connection to evaluation unit

Mounting conditions

The sensor tip should be placed in the midst of the pipe and must be bathed completely from the medium. Please provide a straight pipe: 5x the pipe diameter before and after the sensor device.

Dimensioned drawings: see page 140

Technical data of evaluation unit

Power supply

230 V AC or 24 V AC/DC
(see Product Summary)

Power consumption approx. 3 VA

Contact load

Relay, single pole 8 A, max. 250 VAC

Ambient temperature 0 – 60°C

Flow rate

Adjustable from 0.1 to 20 m/s for gaseous media

Response time 1...5 s

Temperatures > 80 °C, degree of contamination and flow velocity will reduce the response time.

Repetition accuracy

<2%, relative to the flow rate directly on the sensor.

Switching hysteresis approx. 2% of overall range

Max. cable length between sensor and evaluation unit
100 m, for shielded cable 1.5 mm².

Sensor protection

In case of breakage or interruption of the sensor wires, the unit switches off or an interruption of flow is signaled.

Type of construction Standard housing N 45

Weight approx. 0.35 kg

i Function

The air flow monitors work according to the calorimetric principle. A thermistor is heated up. As heat is withdrawn by the flowing air, the thermistor resistance alters. The change in resistance is evaluated. As the resistance also depends on the temperature of the medium, the difference must be determined by a second thermistor. The difference is compensated and in this way the switching point is kept stable. Suspended materials adhering to the sensor can have an insulating effect and so affect the measurement result and hence the defined switching point. Therefore it is advisable to remove any dirt during routine maintenance operations.

Switch-on bypass

While the plant is being started up (still no airflow present), the output contact is activated and the flow condition signaled. The time for the switch-on bypass is adjustable from 2-60 s. The start-up or switch-on bypass starts when the unit is switched on. If an external start button (normally closed contact) is connected (to the Z-Z terminals), the start-up bypass begins when the (locking) button is pressed.

Product Summary

| Type | | Supply voltage |
|-----------|-----------------|----------------|
| SLF15 | Sensor | – |
| ASL453 | Evaluation unit | 230 V AC |
| ASL453/24 | Evaluation unit | 24 V AC/DC |

Operator interface

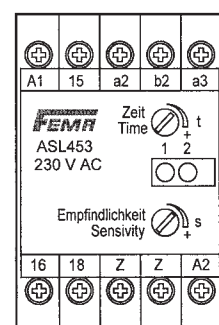

Adjusting elements

- s = sensitivity
t = time for switch-on bypass
(high sensitivity at low flow)

Signal lamps

- 1 = Flow present or switch-on bypass active
2 = supply voltage present

Wiring diagram

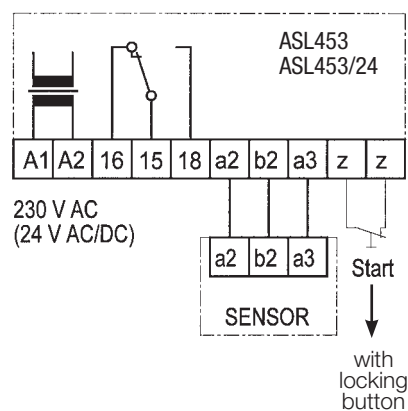

i In case of malfunction, a sensor error can be ruled out by checking the resistances between the connecting wires. Sensor SLF15 must be disconnected and checked with a suitable ohmmeter between the individual connecting wires:

Black-brown approx. 8.2 kOhm
Black-grey approx. 8.2 kOhm
Brown-grey approx. 18 kOhm

The terminal voltage of evaluation units ASW454 or ASW454/24 can also be checked with a voltmeter between the "a2" and "a3" terminals after disconnecting the sensor. 31.4 VDC is the correct value.