

LONMARK® Terminal Unit Controller

IQL15+ LONMARK Terminal Unit Controller



Description

The IQL15+ is a terminal unit controller which can be networked using a LONWORKS® network. It can communicate with other IQLs and LONMARK devices using a LONWORKS network, and with IQ system networked devices using 3xtend/EINC L or LINC. It has 3 relay outputs (normally to control fan speed), and 4 triac outputs (normally to control valves or dampers). A fourth relay is used either as an electric heater output (/E version) or as an auxiliary contact output (/AUX version). It has 3 variable resistance inputs of which the first is normally a thermistor temperature sensor. There are also 2 digital inputs for monitoring manual buttons or alarm contacts; one of these (IN4) can be used to connect a Room Display.

Features

- Low cost terminal unit controller.
- Fully compatible with the IQ system.
- *LONMARK certified.
- No binding for network of only IQ system devices.
- Non-volatile memory, no battery required.
- 230 Vac or 24 Vac input power versions.
- Compatible with Room Display (RD-IQL).
- *Conforms to LONMARK profile 8501.

* Note that LONMARK certification does not apply to custom strategies.

Physical

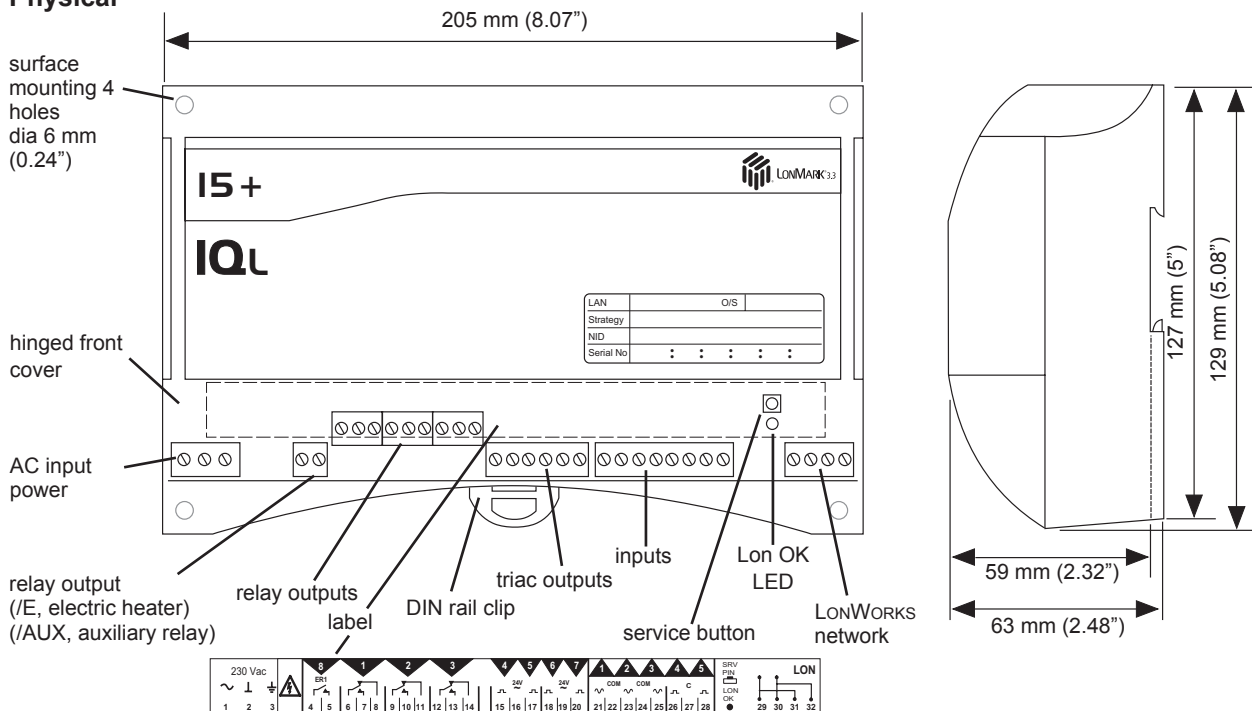

FUNCTIONALITY

The IQL15+ consists of a generic IQL series shell (core hardware and firmware) with specific additional hardware. It is supplied complete with a pre-programmed strategy which defines its HVAC equipment interaction. If the unit is ordered with a standard strategy (e.g. IQL15+/WR4), the standard generic strategy is installed and configured for the required standard strategy; this can be changed to one of the other standard strategies using text communications. The generic strategy is defined in the IQL15+/xxx Standard Strategies Data Sheet, TA200367.

FIRMWARE

The following modules are available for configuration by terse text comms. They are described in the IQ System LONWORKS Products Engineering Manual TE200292.

Core modules

Address module (R); Analogue array (A); Digital array (B)
Time (T)

Strategy modules

Sensor (S), (analogue - thermistor, potentiometer, or fan speed switch); Sensor (S), (internal); Loop (L); User (U)
Logic (G), (combination, timer, hours run)
Function (F), (hysteresis, gate, multiplier, adder, A to D, square root, filter, rescale to, comparator)
Switch (W); Knob (K); Driver (D), (digital, raise/lower, time prop., multi state relay and cascade relay); Digital Input (I)
IC Comms (N); Plot channel (P); Display (~); Directory (@)

Compatibility

The IQL will identify itself as an IQL to w comms. The 945 should be set up to detect it as an IQ151 V7.

Alarms

The IQ system LONWORKS Products Engineering Manual fully describes alarms.

The IQL generates network alarms as follows (if appropriate alarm target address and Lan number are set up in address module):

"IQL -Rem LAN From yyy on Lan xxx-

LON LAN Broken NKBK" - a break in Lan communications
LON LAN Changed NKCH" - a node has gone from or been added to the Lan

LON LAN OK NKOK" - Lan communications are restored

"IQL - Int'wrk From yyy on Lan xxx-

LON lwrk Broken NKBK" - a break in internetwork communications

LON lwrk Changed NKCH" - a node has gone from or been added to the internetwork

LON lwrk OK NKOK" - internetwork communications are restored

The IQL generates the following input alarms. They will be sent to Own Lan alarm reporting address and Lan number if these are set up in the address module:

Sensor alarms:

SENSOR FAIL occurred (OUTL),
SENSOR FAIL cleared (COUT),
INPUT ERROR occurred (READ),
INPUT ERROR cleared (O/K).

Digital input alarms:

DIGIN OFF occurred (DI=0)
DIGIN OFF cleared (CDI0)
DIGIN ON occurred (DI=1)
DIGIN ON cleared (CDI1)

They are same format as IQ alarms except that time and date fields are filled with spaces.

HARDWARE

Unit

The IQL15+ is a small terminal controller designed for surface or DIN rail mounting inside an enclosure conforming to EN61010-1. It has a plastic housing with a hinged clear polycarbonate terminal cover and 4 point surface mounting.

Input Power

The IQL15+ has both 230 Vac and 24 Vac input power options.

/230: This option requires 230 Vac +15% -10%, 50/60 Hz at up to 17.5 VA, which consists of up to 8.5VA internal power, plus the power required by the triac (valve or damper) 24 Vac outputs which is up to of 400 mA.

/24VAC: This option requires 24 Vac ±15%, 50/60 Hz, at up to 15.4 VA, which consists of up to 9.7 VA internal power, plus the power required by the triac (valve or damper) outputs which is up to 400 mA. The 24 Vac input power neutral must be earthed, grounded, at the transformer secondary. The acinput power neutral is internally connected to the IQLelectronics earth, ground. Several IQLs may be supplied in parallel.

The IQL input power earth, ground, terminal is isolated from the supply neutral, and is connected to the chassis; this must be separately earthed, grounded, locally.

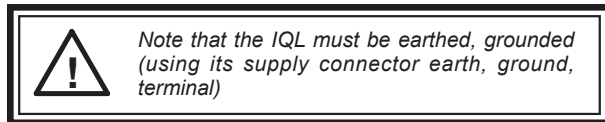

The internal supply is protected by an internal solid state self-resetting thermal device rated at 900 mA.

Note that for the /USA/UL/24VAC the input power connections must be made using 18 AWG or larger wire rated at least 90°C.

Service Button

This is used during the installation of the IQL into a LONWORKS network management tool. This is only necessary under conditions described in the LONWORKS integration section below. During the installation process, the tool will request to be informed of the presence of the IQL; this is done by pressing the 'service' button (see the IQL15+/xxx Installation Instructions TG200344 for full details of this procedure). Pressing the button also generates an alarm message forwarded by 3xtend/EINCL or LINC to its target alarm address (if set up) which identifies IQL by means of its Neuron® chip ID; this can be used as an attribute to find the IQL's device address and Lan number.

LONWORKS

The integral LONWORKS transceiver uses FTT (or LPT) which has the following features:-

- (1) Use of free bus topology enabling star, bus, or loop wiring simplifies installation and facilitates network expansion.
- (2) The bus uses two wires (twisted pair) which are polarity independent with no need for screen.
- (3) The FTT runs at 78 k baud.
- (4) The FTT LONWORKS network may already be present in a building, so the IQ system is able to make use of an existing building bus and hence reduce installation cost.

Lon OK Indicator

It flashes approximately every 24 s while the local Lan of IQLs is being built, after which it stays on indicating that the IQL has successfully communicated with at least one other IQ system device on the LONWORKS network. If the IQL does not receive any messages (i.e. a deaf IQL), it will flash every second.

Backup

The data (shell firmware, strategy, parameters, logged data) is stored in flash memory which is non-volatile in the case of power failure. The flash memory is only written to at midnight or after a write to the address module in order to prolong the life of the flash memory. Any changes to sensor or driver types should be terminated by a text comms reset command R(z=1) to immediately write the changes to flash and reset the unit; note that this command clears logged data and sets the time to zero. Any other parameter changes (other than address module changes and changes to current time) should be terminated by the text comms command R(z=0) to immediately write the changes to flash.

Outputs

Relay Outputs (OUT1, 2, 3 - e.g. fan speed switches)

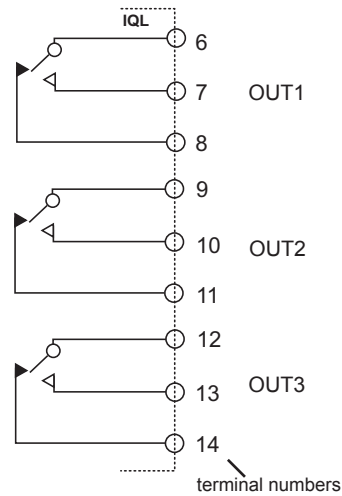

Triac Outputs (OUT4, 5, and OUT6, 7 - e.g. raise/lower valves)

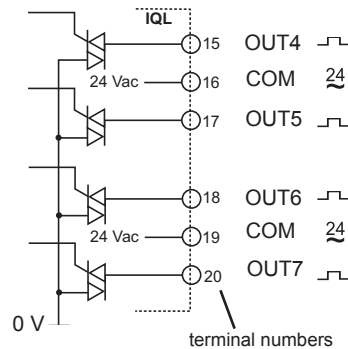

Relay Output (OUT8)

- e.g. electric heater (/E version) or auxiliary relay (/AUX version)

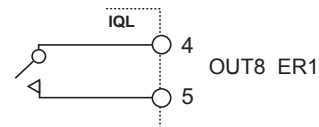

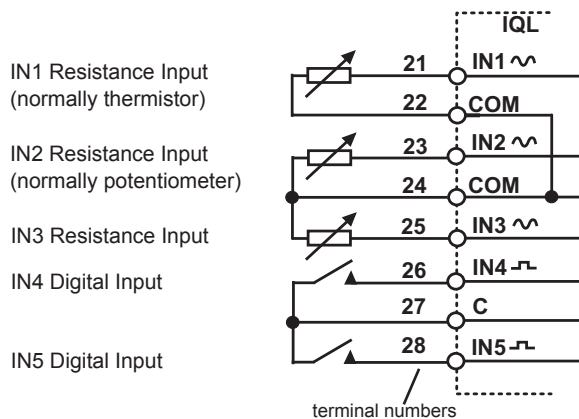
HARDWARE (continued)**Inputs****Inputs 1, 2, 3**

Variable resistance (analogue) inputs, 0 to 29 k Ω . The use of the inputs is defined by the strategy; the following are examples.

Thermistor temperature sensor input (normally input 1). Thermistor inputs are scaled for a standard IQ system thermistor (10 k Ω at 25 °C, 77 °F). Scaling range 2.5 °C to 60 °C (36.5 °F to 116 °F). Conversion accuracy ± 0.25 °C (± 0.45 °F) over range (10 °C to 30 °C, 50 °F to 86 °F).

Potentiometer input (normally input 2). Scaled for standard IQ system potentiometer (1 k Ω to 11 k Ω). A potentiometer input is automatically self calibrating to give 0% to 100% of adjustment over full range of potentiometer. If required calibration may be set by turning potentiometer to both ends of range, and waiting 6 secs at each endpoint.

Fan Speed Control input (normally input 3). Input resistance is set to one of five values by an external switch and decoded to give required fan speed selection (Off, Low manual, Medium manual, High manual, and Auto).

Input 4

Volt free contact (digital) input. 12 Vdc supply at 20 mA. Input 4 provides a TBus connection for use by the RD-IQL (room display).

Input 5

Volt free contact (digital) input. 5 Vdc supply via 10 k Ω . Wetting current 0.5 mA.

Displays

The RD-IQL/K (Room Display) is a wall mounting temperature sensor and 3 digit display with control and indication of setpoint. The RD-IQL/KOS also provides an occupation override switch and indication. The RD-IQL/KOSF also provides fan speed control and indication. The RD is connected to IN4. Some IQL configuration parameters must be changed for an RD-IQL to operate with the IQL (see strategy data sheet).

Connecting an RD renders some of the normal features inoperative:

RD-IQL/K: The RD's potentiometer must be used, not IN2 (if a potentiometer is required). A separate sensor connected to IN1 may be used instead of the RD's; this is achieved by maintaining the normal sensor type for IN1. There will be no PIR or pushbutton input. A fan speed switch connected to IN3 may be used.

RD-IQL/KOS: The same as for RD-IQL/K but the /KOS gives use of its pushbutton.

RD-IQL/KOSF: The same as for RD-IQL/KOS but the /KOSF gives use of its fan speed switch. A separate fan speed switch connected to IN3 may be used instead of the RD's; this is achieved by maintaining the normal sensor type for IN3.

The SDU-LON (Smart Display Unit) is a wall mounting electroluminescent display that can be connected to the LONWORKS bus and 'attached' to its IQL. It enables the user to view and adjust selected parameters within the controller. The SDU-LON has a real time clock that can set the controller's time, it also provides it with a time zone and calendar features (see SDU data sheet TA200559).

Sensors

The TB/TS provides a wall mounting thermistor space sensor that can be connected to the IQL15+ input 1 (see TB/TS data sheet TA200603). The TB/TS/K also provides setpoint adjustment to connect to input 2. The TB/TS/KE has the TB/TS/K features plus an occupation override pushbutton to connect to input 4. The TB/TS/KEF has the TB/TS/KE features plus a fan speed control switch to connect to input 3.

SYSTEM

Full system details are covered by IQ System LONWORKS Product Engineering Manual

LONWORKS bus

The IQL is an IQ controller which uses the LONWORKS bus as its communications network. It is LONMARK certified and will communicate with other LONWORKS devices.

LONWORKS Integration

In a LONWORKS system consisting only of IQ system devices no LONWORKS installation is required as IQ system LONWORKS products self-install. Installation onto a LONWORKS network management tool is only necessary if it is required to bind LONMARK devices to the IQL strategy modules, if LINC's, pre-version 3.23, straddle a router, if other devices on the LONWORKS network have address conflicts with IQ system LONWORKS devices, or LONWORKS routers (e.g. IQLROUTERS) are used on an installed system. If one IQ system LONWORKS device is installed, all IQ system LONWORKS devices must be installed.

From a LONWORKS network perspective the IQL is supplied in a configured state i.e. it will install on the network with its address set up and communicate using IQ system communications. It can be set to an unconfigured state using a LONWORKS Management Tool.

IQL address

The IQL device and Lan number are set up in the factory on a rolling basis, so in a batch of IQLs, each will have a different factory address (printed on the unit's label along with its Neuron ID). IQ system LONWORKS devices on the same Lan must be on same LONWORKS subnet (and hence same side of LONWORKS router). An IQL may be re-addressed by terse text comms (IqlTool2 recommended). New addresses should be written on the unit's label; a tear-off adhesive label strip with unit ID and address information can be used for a paper record e.g. log book.

Communication

The 3xtend/EINC L or LINC acts as an interface between the IQ system Lan and the LONWORKS bus. It enables IQLs to communicate with IQ system Supervisors by terse text comms and with IQ system IQs using IC Comms. The 3xtend/EINC L is the preferable interface, but if the system is installed on a LONWORKS Management Tool, the LINC must be used. If the IQL is bound to other LONMARK devices it communicates with them using Network Variables (NVs) as shown in accompanying table. The binding to a variable is done by using both SNVT (standardised network variable type) and NV name for each variable. All the network variables are described in the manual TE200292. Those required for the LONMARK node and the LONMARK profile 8501 compatibility are shown in the adjacent table (custom strategies may not have these variables).

IqlTool2

IqlTool2 software tool connects directly to the LONWORKS segment using the LCI (LONWORKS Comms Interface) using adapter cables supplied with the interface.

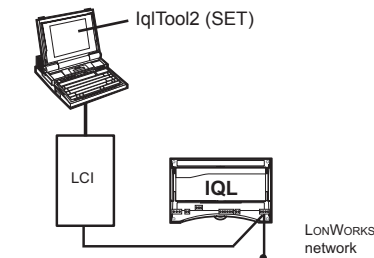

It runs on a PC on which SET v5.1 or greater has been installed. IqlTool2 facilitates mapping the LONWORKS segment, resolving duplicate addresses on the LONWORKS network, water balancing (/WR2, /WR4, /WT2, /WT4 only), identifying using service button, associating with SDU-LON, monitoring inputs and exercising outputs, setting as a timekeeper, and configuring for RD. It provides access to text communications for changing module parameters (e.g. knobs, switches, changing a generic strategy).

nv name	SNVT	Strategy Var.	Label
LONMARK Node			
Mandatory Network Variables			
nviRequest	SNVT_obj_request		
nvoStatus	SNVT_obj_status		
Optional Configuration Properties			
nciNetConfig	SNVT_config_src		LONWORKS Managed
nciMajDevVer	SNVT_count		
nciMinDevVer	SNVT_count		
Manufacturer Defined Section			
nciDomainIndex	SNVT_count		LONWORKS domain index
nciDomainWide	SNVT_lev_disc		LONWORKS domain wide
nciMsgCode	SNVT_count		LONWORKS message code
nciBufferSize	SNVT_count		Router buffer size
nviCurrDateTime	SNVT_time_stamp		
nviSecurity Code	SNVT_count		
nvoGenerator	SNVT_count		
LONMARK Profile 8501			
Mandatory Network Variables			
nviSpaceTemp	SNVT_temp_p	K2	RemoteSpaceTemp
nvoSpace Temp	SNVT_temp_p	S1	Space Temp
nvoUnitStatus	S N V T _ h v a c _ status		
Optional Network Variables			
nviSetpoint	SNVT_temp_p	K1	Remote Setpoint
nviSetptOffset	SNVT_temp_p	K8	Remote SP Offset
nviOccManCmd	SNVT_occupancy	K6	Remote Occ
nviFanSpeedCmd	SNVT_temp_p	K7	Remote Fan Spd
nvoEffectSetPt	SNVT_temp_p	S2	Setpoint
nvoEffectOccup	SNVT_occupancy	S3	Occupancy
nvoFanSpeed	SNVT_switch	S6	Fan Speed
nvoHeatPrimary	SNVT_lev_percent	S4	Heating Demand
nvoCoolPrimary	SNVT_lev_percent	S5	Cooling Demand
Mandatory Configuration Properties			
nciSndHrtBt	SNVT_time_sec		
nciSetpoints	SNVT_temp_setpt		
Optional Configuration Properties			
Manufacturer Defined Section			
nvoA7	SNVT_temp_p	S7	Effect Fan Speed
nvoA8	SNVT_temp_p	S8	
nviA19	SNVT_temp_p	K3	OCC Deadbnd
nviA20	SNVT_temp_p	K4	Standby Deadbnd
nviA21	SNVT_temp_p	K5	NOCC Deadbnd
nviB18_0	SNVT_switch	W1	O=4Pipe I=2Pipe
nviB18_1	SNVT_switch	W2	Summer Mode
nviB18_2	SNVT_switch	W3	Elec Disable
nviB18_3	SNVT_switch	W4	O=Water I=Air
nviB18_4	SNVT_switch	W5	Window Mode
nviB18_5	SNVT_switch	W6	O=Pb I= PIR
nviB18_6	SNVT_switch	W7	Frost Condition
nviB18_7	SNVT_switch	W8	Remote Shutdown
nvoB1_0	SNVT_switch	I1	Fan Enabled
nvoB1_1	SNVT_switch	I2	Unit Occupied
nvoB1_2	SNVT_switch	I3	Unit Unoccupied
nvoB1_3	SNVT_switch	I4	
nvoB1_4	SNVT_switch	I5	Unit in Standby
nvoB1_5	SNVT_switch	I6	
nvoB1_6	SNVT_switch	I7	
nvoB1_7	SNVT_switch	I8	

Table of Network Variables for IQL15+

INSTALLATION

The IQL15+ must be installed inside an enclosure conforming to EN61010-1.

The /USA/UL/ 24VAC unit is rated as 'UL916 listed open energy management equipment'.

It should be mounted either on DIN rail or flat surface (via 4 hole mounting). The installation involves the following procedure:

- Mount the unit in position
- Connect input power (do not switch on)
- Earth (ground) unit
- Connect LONWORKS network
- Connect I/O
- Switch on power to unit
- Check IQ system communications
- Configure core module parameters if required
- Install on LONWORKS Management Tool if required (see LONWORKS integration above) and bind any network variables.
- Configure strategy parameters if required
- Configure rest of system
- Test system

Note: If installation on a LONWORKS ManagementTool is required, the installer must have LONWORKS engineering expertise

The installation procedure is covered by IQL15+/xxx Installation Instructions, TG200344. If supplied with a custom strategy, also see appropriate strategy installation instructions.

CONNECTIONS

Input Power

/230 230Vac

WARNING: This apparatus must be earthed, grounded. (using earth, ground, terminal)

Clean earths, grounds, consisting of short <300 mm, 12" stranded copper (>=1.5 mm, 16 AWG) wired to a substantial earthed, grounded, point (e.g. cable tray) are recommended.

/24VAC 24 Vac

Class 2
Earth, ground, 24 Vac supply neutral at transformer

Note that for /USA/UL/24VAC cable rating 1.0mm² (18 AWG or less) rated at least 90°C.

LONWORKS network

The LONWORKS network has free bus topology

*Terminate LONWORKS bus at one end only

Terminator e.g. LONTERMINATOR

52.3 Ω ±1%
100 μF, 50 V min

polarity independent

Recommended cables shown in specification section below. Do not use screened cable.

Do not allow wires to cross on a loop

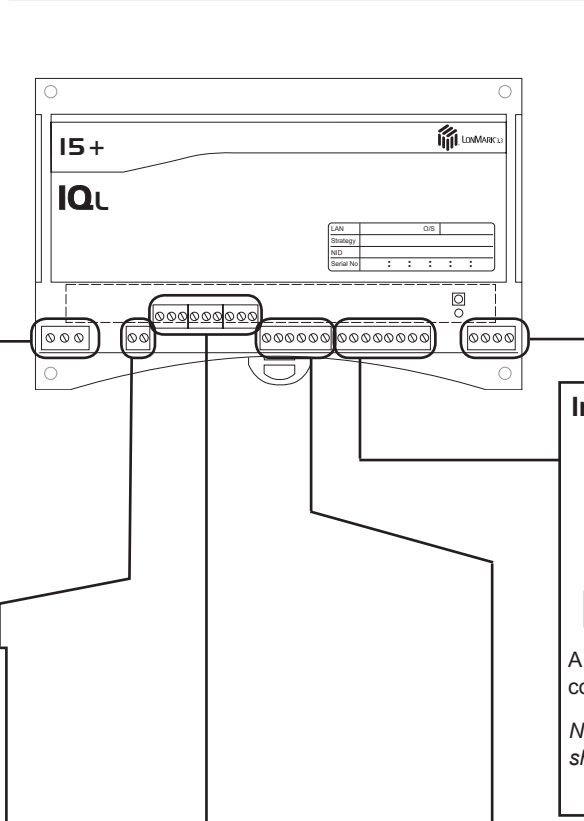

Inputs

1	2	3	4	5
~	COM	~	COM	~
21	22	23	24	25
~	~	~	~	~
26	27	28		
~	~	~		

A room display (RD) can be connected to IN4.

Note that terminal types COM and C should not be connected together.

Relay Output

(10 A max.)

Electric Heater (/E only)
If switching an electric heater, a suitably rated thermal cutout should be fitted in series with the heater supply.

Auxiliary Relay Output (/AUX only)

Relay Outputs (5A max.)

Triac Outputs

400 mA max. shared between all triac outputs used

See strategy data sheet for input/output connection details.

DISPOSAL

COSHH (Control of Substances Hazardous to Health - UK Government Regulations 2002) ASSESSMENT FOR DISPOSAL OF IQL CONTROLLER. No parts affected.

RECYCLING

All plastic and metal parts are recyclable. The printed circuit board may be sent to any PCB recovery contractor to recover some of the components for any metals such as gold and silver.

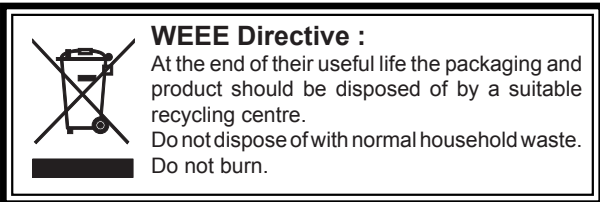

ORDER CODES

IQL15+/[strategy]/[option]/[power]

e.g. IQL15+/WR4/E/24VAC

:IQL15+ controller with 24 Vac supply and generic strategy set for Water Side, 4 Pipe, Raise/Lower (floating point) with Electric Heater output. (Not available in USA.)

e.g. IQL15+/AR2/E/USA/UL/24VAC

:IQL15+ controller with 24 Vac supply and generic strategy set for Airside, Riase/Lower (floating point), with electric heater output for USA. UL rated.

[strategy]	[option]		[power]	
For standard strategies and options, see IQL15+/xxx Standard Strategies Data Sheet TA200367	/E	Electric Heater output	/24VAC	24 Vac Supply
	/AUX	Auxiliary Relay output	/230	230 Vac Supply

LONTERMINATOR

:Universal LONWORKS terminator (see LONTERMINATOR data sheet, TA200229).

SDU-LON

:Wall mounting Smart Display unit enables display and adjustment of control parameters. Connects to a LONWORKS network. (Not available in USA.)

SDU-LON/WSA/USA

:Wall mounting Smart Display unit enables display and adjustment of control parameters, with wall sensor adaptor plate. Connects to a LONWORKS network.

IQLROUTER/24VAC

:IQL Router with 24Vac power option. (Not available in USA.)

IQLROUTER/230

:IQL Router with 230 Vac power option. (Not available in USA.)

IQLROUTER/USA/UL/24V

:IQL Router with 24Vac power option for USA.

TB/TS

:Wall mounting thermistor space temperature sensor.

TB/TS/K

:As TB/TS plus setpoint adjustment.

TB/TS/KE

:As TB/TS/K plus occupation override push button.

TB/TS/KEF

:As TB/TS/KE plus fan speed control switch.

RD-IQL/K

:Wall mounting Room Display comprising temperature sensor, 3 digit display with control and indication of setpoint. (Not available in USA.)

RD-IQL/KOS

:As RD-IQL/K plus occupation override switch and indicator. (Not available in USA.)

RD-IQL/KOSF

:As RD-IQL/KOS plus fan speed control and indicator. (Not available in USA.)

RD-IQL/K/WSA/USA

:As RD-IQL/K with wall sensor adaptor plate for USA

RD-IQL/KOS/WSA/USA

:As RD-IQL/KOS with wall sensor adaptor plate for USA

RD-IQL/KOSF/WSA/USA

:As RD-IQL/KOSF with wall sensor adaptor plate for USA

WSA/10/USA

:Pack of 10 wall sensor adaptor plates to facilitate mounting SDU/RD on US or Danish wall boxes. Each plate complete with 2 plastic covers, 2 back box screws, and two 3.5 mm SDU/RD screws.

***3XTEND/EINC L/230**

:Node controller which enables LONWORKS bus to be used as part of IQ System. Connects IQLs to IQ System current loop network and Ethernet. 230Vac power. (Not available in USA.)

***3XTEND/EINC L/24**

:Node controller which enables LONWORKS bus to be used as part of IQ System. Connects IQLs to IQ System current loop network and Ethernet. 24 Vac power. (Not available in USA.)

***3XTEND/EINC L/USA/UL/24**

:UL rated node controller which enables LONWORKS bus to be used as part of IQ System. Connects IQLs to IQ System current loop network and Ethernet. 24 Vac power for USA.

***NETB/LINC/FTT/230**

:Node controller which enables LONWORKS bus to be used as part of IQ System. Connects IQLs to IQ System current loop network, 230 Vac power. (Not available in USA.)

*Note that the 3xtend/EINC L should be used as preference; LINC must be used if system installed on a LONWORKS Management Tool

LCI/USB

:LONWORKS Commissioning Interface. Portable LONWORKS node which connects to PC to a LONWORKS network using a USB connection.

TP/1/0/16/HF/200

:200 metres (218 yds) unscreened single twisted pair cable suitable for wiring LONWORKS bus. (Not available in USA.)

SPECIFICATIONS

Electrical

Input Power Supply

/230 :230 Vac -10% +15%, 50/60 Hz

/24VAC :24 Vac \pm 15%, 50/60 Hz

Input Power Supply Consumption

/230 :Up to 17.5 VA which consists of 8.5 VA internal power plus power to triac outputs.

/24VAC :Up to 15.4 VA which consists of 9.7 VA internal power plus power to triac outputs. In both cases the maximum current shared between the triac outputs is 400 mA.

CPU :3 processor Neuron chip

Memory :64 kbytes flash memory, 8 kbytes RAM

Battery :no battery required (data stored in flash memory)

Clock :software clock (1 minute resolution)

LONWORKS network :FTT - Free topology, 78 k baud, transformer isolated. Single termination (RC network). Can also use loop powered free topology, LPT.

LONWORKS FTT distance :Maximum bus length, node to node distance depends on cable type:

Recommended Cables	Max bus length	Max node to node
Belden 85102	500 m (545 yds)	500 m (545 yds)
(Belden 8471)	500 m (545 yds)	400 m (430 yds)
UL Level IV, 22 AWG	500 m (545 yds)	400 m (430 yds)
JY(St) Y2 x 2 x 0.8	500 m (545 yds)	320 m (350 yds)
TIA568A Cat. 5, 24 AWG	450 m (490 yds)	250 m (270 yds)

Note that this does not include cable recommended for the IQ system current loop Lan.

Fuse :Solid state self-resetting, protects at 500 mA.

Inputs

IN1, 2, 3 :Variable resistance inputs, 0 to 29 k Ω , Bridge supply 5 Vdc.

IN4 :Volt free contact inputs. 12 Vdc supply at 20 mA. IN4 provides TBus for connection of RD.

IN5 :Volt free contact inputs. 5 Vdc supply through 10 k Ω . Wetting current 0.5 mA.

Outputs

OUT1, 2, 3 :Digital outputs: Changeover relay contacts. Output rated at 5 A maximum at 240 Vac ($\cos\phi \geq 0.4$), and 24 Vdc (resistive load). Reduce to 2 A for 24 Vdc (inductive load, $T \leq 30$ ms). For /USA/UL/24VAC rating applies up to 30V. Arc suppression circuit (RC) should be fitted for inductive loads, see TG200208

Note that to meet safety requirements, for the 4 relays (OUT1 to OUT3, OUT8), those being used must all be switching either low voltage or mains and not a mixture of voltages. If switching mains, they must all switch the same phase and polarity.

OUT4/OUT5
OUT6/OUT7 :Triac outputs equivalent to 24 Vac solid state relays. Total of 400 mA shared between all four triac outputs.

OUT8 :Digital output: Normally open, relay contacts. Output rated at 10 A maximum at 240 Vac ($\cos\phi \geq 0.4$). For /USA/UL/24VAC, rating applies up to 30 Vac. Arc suppression circuit (RC) should be fitted for inductive loads, see TG200208.

Note that to meet safety requirements, for the 4 relays (OUT1 to OUT3, OUT8), those being used must all be switching either low voltage or mains and not a mixture of voltages. If switching mains, they must all switch the same phase and polarity.

Mechanical

Dimensions :205 mm (8.07") x 129 mm (5.08") x 63 mm (2.48")

Material

Box :Flame retardant ABS

Terminal Cover :Clear polycarbonate flap

Weight :896 g (1lb 15.5 oz)

Connectors :two part for 0.14 to 2.5 mm² cross section area (25 to 14 AWG) cable (for USA/UL/24VAC use 22 to 14 AWG).

Environmental

EMC :EN61326 - 1: 2006

Immunity :(Table 2) for equipment used in industrial locations

Emissions :EN55011: 2007 Class B

:EN61000-3-2: 2006

:EN61000-3-3 +2A: 2005

Safety

EU :EN61010-1: 2001

USA Canada :(/USA/UL/24VAC only) UL rated as 'UL916 listed open energy management equipment'.

Ambient limits

storage :-10 °C (14 °F) to 50 °C (122 °F)

operating :0 °C (32 °F) to 45 °C (113 °F)

humidity :0 to 95 %RH non-condensing

Altitude

:<2000 m

Protection

:IP20, NEMA 1

©Echelon, LON, Neuron, LONWORKS and LONMARK are trademarks of Echelon Corporation registered in the United States and other countries.

Please send any comments about this or any other Trend technical publication to techpubs@trendcontrols.com

© 2012 Honeywell Technologies Sàrl, ECC Division. All rights reserved. Manufactured for and on behalf of the Environmental and Combustion Controls Division of Honeywell Technologies Sàrl, Z.A. La Pièce, 16, 1180 Rolle, Switzerland by its Authorized Representative, Trend Control Systems Limited.

Trend Control Systems Limited reserves the right to revise this publication from time to time and make changes to the content hereof without obligation to notify any person of such revisions or changes.

Trend Control Systems Limited

Albery House, Springfield Road, Horsham, West Sussex, RH12 2PQ, UK. Tel:+44 (0)1403 211888 Fax:+44 (0)1403 241608 www.trendcontrols.com

Trend Control System USA

6670 185th Avenue NE, Redmond, Washington 98052, USA. Tel:(425) 869-3900 Fax:(425) 869-8445 www.trend-america.com