

H7018A1003

EARLY-WARNING DEW-POINT SENSOR

PRODUCT DATA



FEATURES

- Does not wait to detect when the dew-point has already been reached, but rather provides an early warning of the approaching dew-point
- Compact design
- Fast response
- Module is coated, thus protected against contamination
- Simple and easy mounting
- Designed with an interface for direct connection to Honeywell's XL10 – XL500 controllers

SPECIFICATIONS

Supply voltage	24 Vac \pm 20%
Power consumption	< 10 mA
Switch-points	
RH > 90%	contact "open"
RH < 90%	contact "closed"
Switching hysteresis	-4/+5% RH
Output	potential-free contact
Voltage	max. 60 Vdc
Switching current	max. 15 mA
ON voltage	100 mV at 15 mA
Response time	approx. 3 min (given a jump in the relative humidity of from 55% to 100%)
Weight	approx. 120 g
Storage temperature	-10...+70 °C (+14...+158 °F)
Humidity	5...95% RH, non-condensing

APPLICATION

This early-warning dew-point sensor is designed for use in monitoring cooling water pipes or chilled surfaces in order to determine if temperatures are approaching the dew-point. It is suitable for mounting on flat and round surfaces.

The sensor measures the relative humidity prevailing directly at the chilled surface and can thus be used to

- regulating cooling performance,
- switching cooling systems ON and OFF, and
- signalling if the temperature is approaching the dew point.

Using this sensor, it is thus possible to operate e.g. chilled ceilings in an optimal manner and without the formation of condensation water even under critical climatic conditions.

MOUNTING

Using the elastic metal link chain supplied with the shipment, the sensor should be mounted to that part of the pipe or of the flat chilled surface which is most susceptible to the formation of condensation water. The mounting location must be clean, dry, and bare (i.e. uninsulated). Remove the protective film on the adhesive tape before mounting. In mounting, it is important to provide for a good thermal contact between the sensor and the pipe or flat surface.

The sensor is supplied in a pre-calibrated condition and thus need not be adjusted on site.

In the case of pipes having a diameter in excess of 30 mm, use a correspondingly longer fastener (e.g. clamp metal band, etc.)

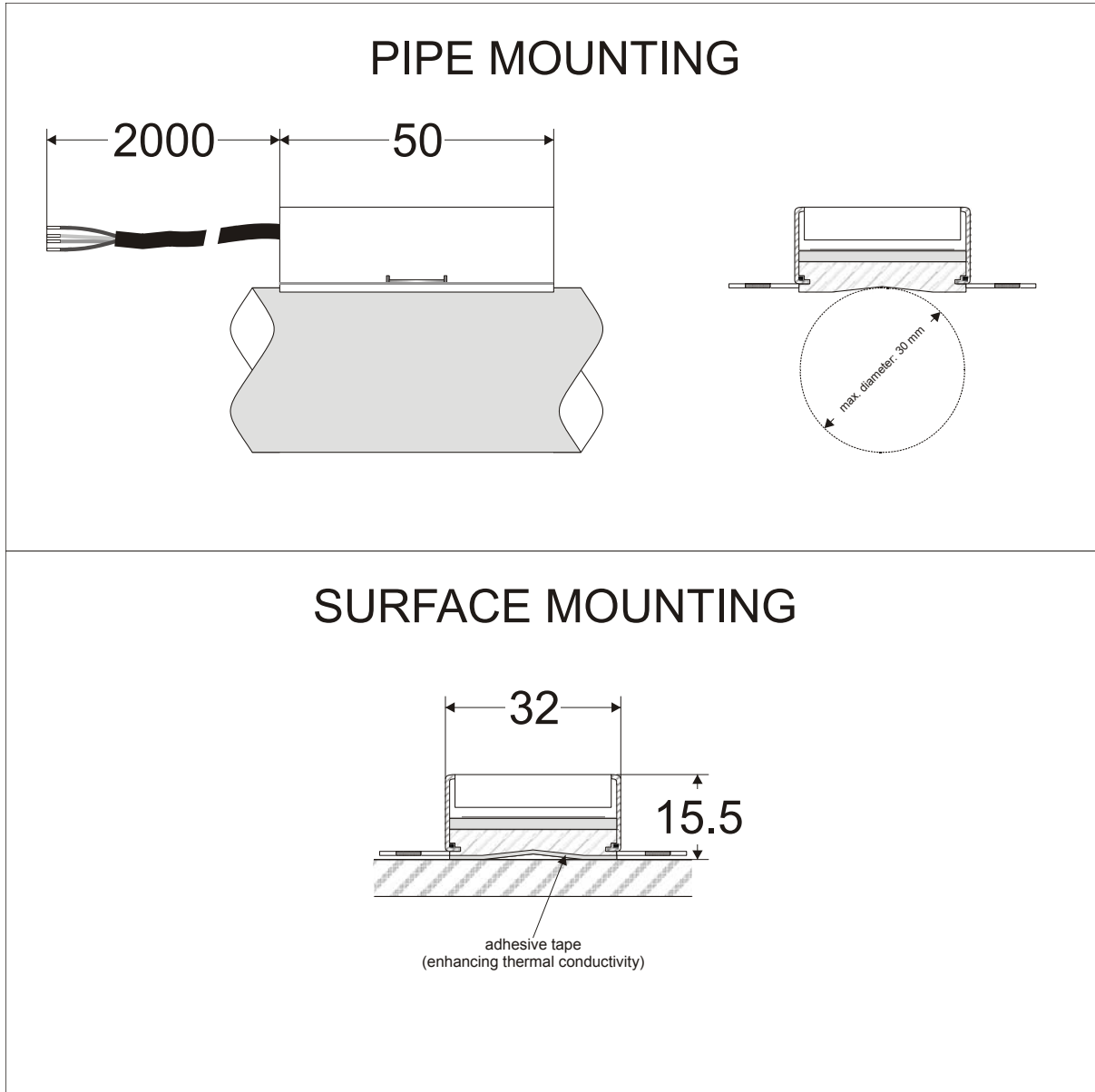

Fig. 1: Mounting (dimensions in mm)

CONNECTION

wire	W7763	XFL523 via XSL513	XFC3D
24 Vac (green)	terminal 11	XSL511 (24 Vdc)	terminal 1
24 V COM (brown)	terminal 12	XSL511 (Vac)	terminal 2
OUT+ (white)	terminal 4	terminal 2 (+18 V)	terminal 6
OUT- (yellow)	terminal 5	terminal 1 (DI1)	terminal 5

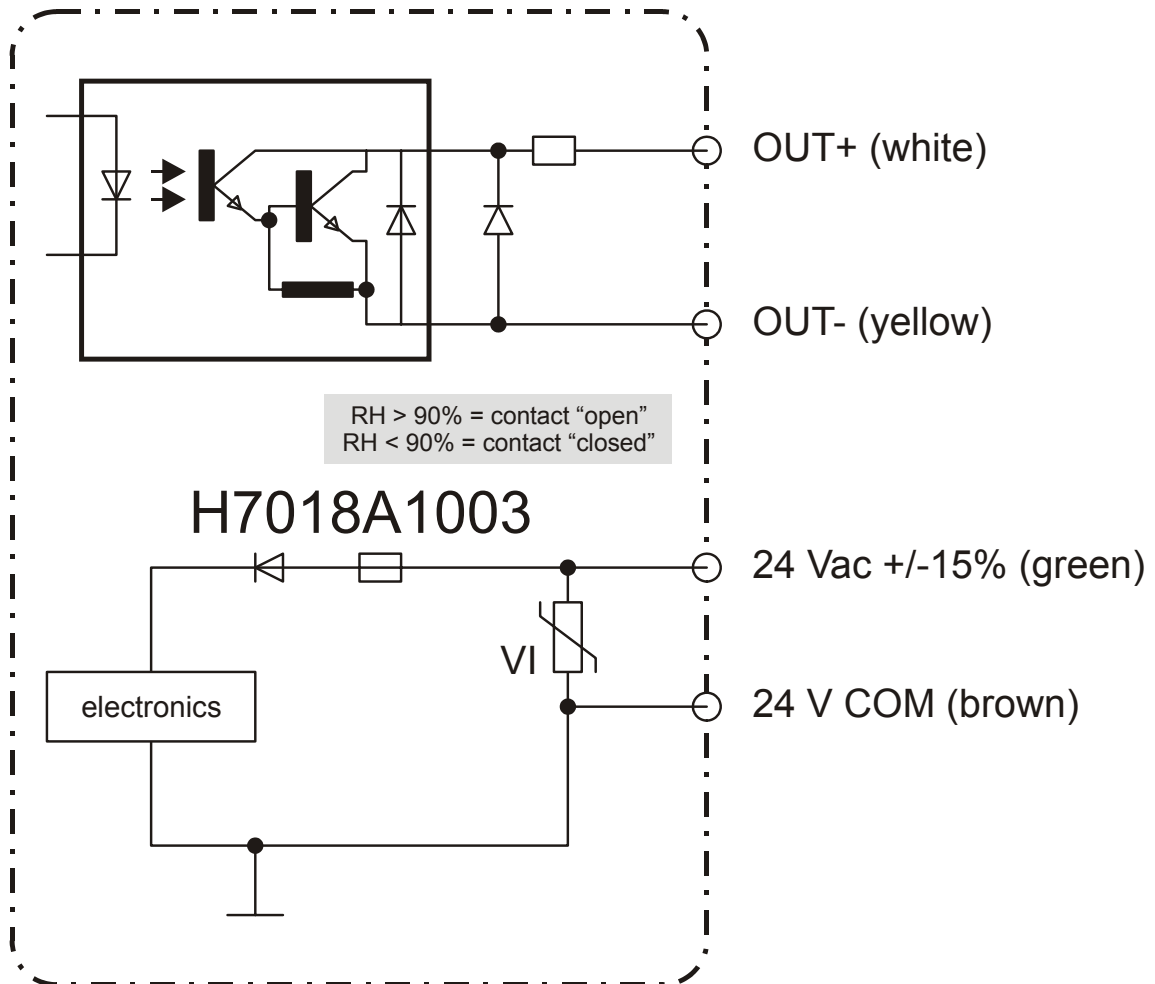

Fig. 2. Internal wiring of the H7018A1003

References

TITLE

Excel 10: W7763C,D,E Chilled Ceiling Controllers – Installation Instructions
 Excel 10: W7763C Flex Sys Controller – Installation Instructions
 Excel 500/600 Control System – Installation Instructions
 Excel Smart I/O (XFC 2AXX, 3AXX, 2DXX, and 3DXX) – Installation Instructions

Product Literature No.

95-7485-3
 EN1B-0213GE51
 EN1R-1047GE51
 EN1B-0180GE51

Honeywell

Automation and Control Solutions

Honeywell GmbH
Böblinger Straße 17
D-71101 Schönaich
Phone: (49) 7031 63701
Fax: (49) 7031 637493
<http://europe.hbc.honeywell.com>

Subject to change without notice. Printed in Germany

EN0B-0449GE51 R0304

Manufacturing location certified to **DIN EN**
ISO 9001